

**A. PROPORTION OF BROKEN ROCK:**

THE PERCENTAGE BY WEIGHT OF MATERIAL IN EACH OF THE FRACTIONS BETWEEN THE 19mm AND 4.75mm SIEVES HAVING TWO OR MORE BROKEN FACES SHALL NOT BE LESS THAN 70%

**B. CRUSHING RESISTANCE:**

THE CRUSHING RESISTANCE SHALL NOT BE LESS THAN 130kN

**C. WEATHERING RESISTANCE:**

THE AGGREGATE SHALL FALL INTO ONE OF THE FOLLOWING WEATHERING RESISTANCE CATEGORIES:- AA AB AC BA BB CA.

**D. SAND EQUIVALENT:**

THE SAND EQUIVALENT SHALL NOT BE LESS THAN 40 WHEN THE AGGREGATE IS TESTED ACCORDING TO NZS 4407: 1991.

**NELSON  
CITY  
COUNCIL**

**20mm BASECOURSE AGGREGATE**

**INFRASTRUCTURAL ASSETS**

APPROVED

SENIOR EXECUTIVE INFRASTRUCTURE

29/07/2010

DATE

**SD 401**

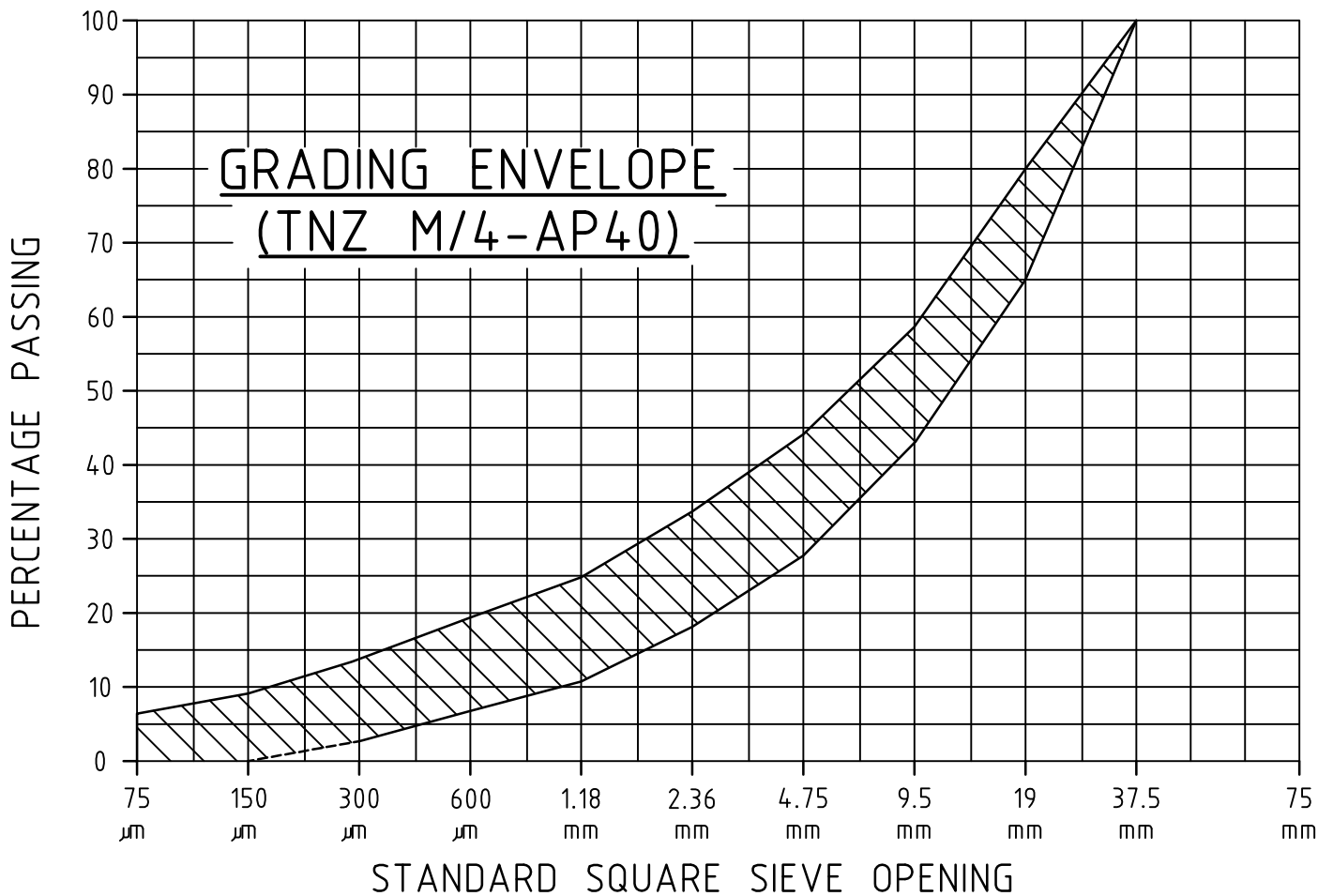

**A. PROPORTION OF BROKEN ROCK:**

THE PERCENTAGE BY WEIGHT OF MATERIAL IN EACH OF THE FOUR FRACTIONS BETWEEN THE 37.5mm AND 4.5mm SIEVES HAVING TWO OR MORE BROKEN FACES SHALL NOT BE LESS THAN 70%

**B. CRUSHING RESISTANCE:**

THE CRUSHING RESISTANCE SHALL NOT BE LESS THAN 130kN

**C. WEATHERING RESISTANCE:**

THE AGGREGATE SHALL FALL INTO ONE OF THE FOLLOWING WEATHERING RESISTANCE CATEGORIES:- AA AB AC BA BB CA.

**D. SAND EQUIVALENT:**

THE SAND EQUIVALENT SHALL NOT BE LESS THAN 40 WHEN THE AGGREGATE IS TESTED ACCORDING TO NZS 4407: 1991.

**NELSON  
CITY  
COUNCIL**

**40mm BASECOURSE AGGREGATE**

**INFRASTRUCTURAL ASSETS**

APPROVED

SENIOR EXECUTIVE INFRASTRUCTURE

29/07/2010

DATE

**SD 402**

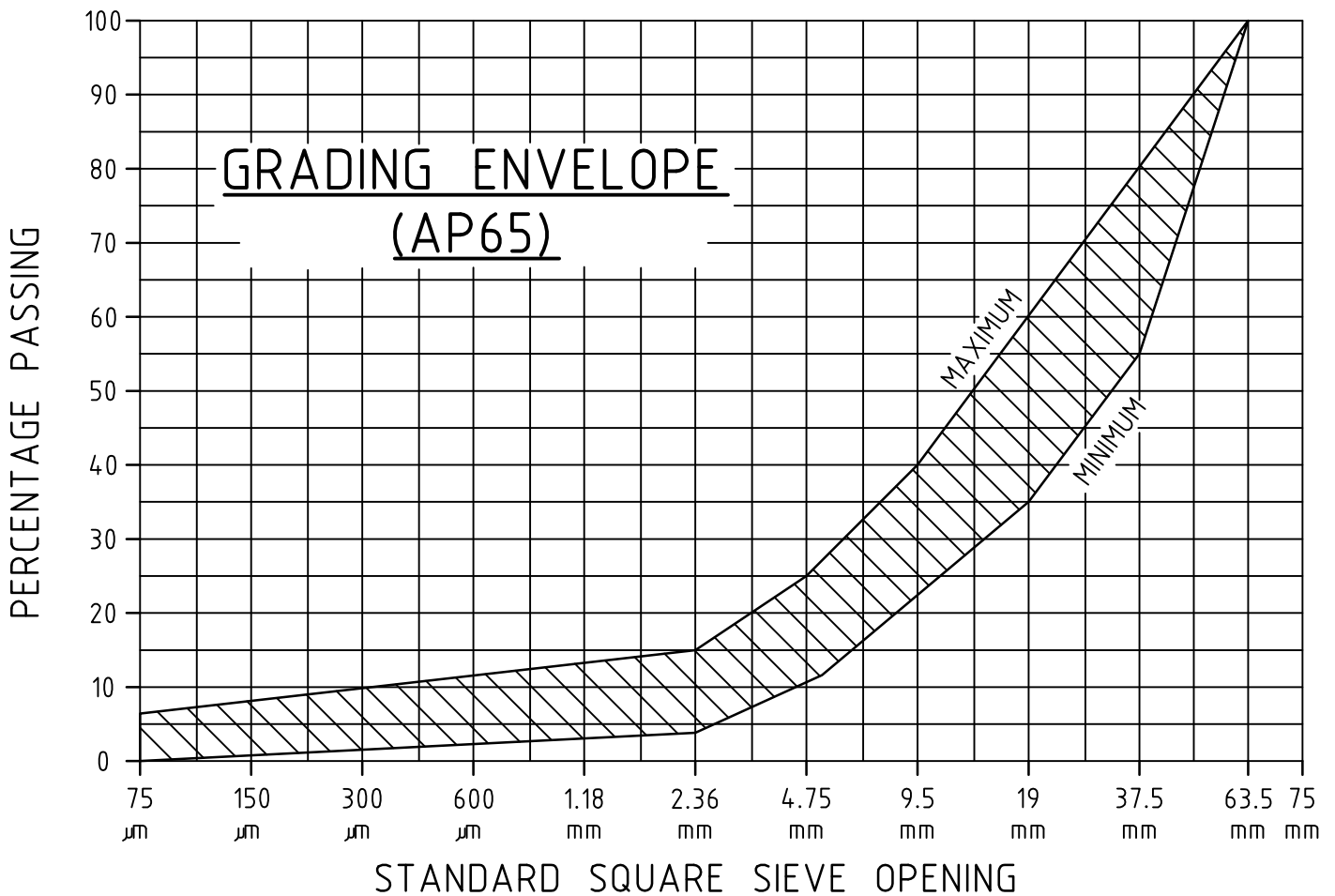

**A. PROPORTION OF BROKEN ROCK:**

THE PERCENTAGE BY WEIGHT OF MATERIAL IN EACH OF THE FOUR FRACTIONS BETWEEN THE 63.5mm AND 4.5mm SIEVES HAVING TWO OR MORE BROKEN FACES SHALL NOT BE LESS THAN 70%

**B. CRUSHING RESISTANCE:**

THE CRUSHING RESISTANCE SHALL NOT BE LESS THAN 110kN

**C. WEATHERING RESISTANCE:**

THE AGGREGATE SHALL FALL INTO ONE OF THE FOLLOWING WEATHERING RESISTANCE CATEGORIES:- AA AB AC BA BB CA.

**D. SAND EQUIVALENT:**

THE SAND EQUIVALENT SHALL NOT BE LESS THAN 40 WHEN THE AGGREGATE IS TESTED ACCORDING TO NZS 4407: 1991.

<b>NELSON CITY COUNCIL</b>	<b>65mm SUB-BASECOURSE AGGREGATE</b>	
	<b>INFRASTRUCTURAL ASSETS</b>	<b>SD 403</b>
APPROVED	 ..... <b>SENIOR EXECUTIVE INFRASTRUCTURE</b>	29/07/2010 ..... <b>DATE</b>

EXAMPLE: (SHOWN IN DOTTED LINE)

RESIDENTIAL ROAD

OBSERVED DEFLECTIONS 3.6mm ADDITIONAL DEPTH OF METALCOURSE REQUIRED = 210mm

NOTE: MINIMUM M/4 AP40 BASECOURSE LAYER REQUIRED IS 100mm FOR CONCRETE FOOTPATHS, 150mm FOR ASPHALTIC CONCRETE FOOTPATHS & RESIDENTIAL ROW's, 200mm FOR ROADS & COMMERCIAL/INDUSTRIAL PRIVATE WAY

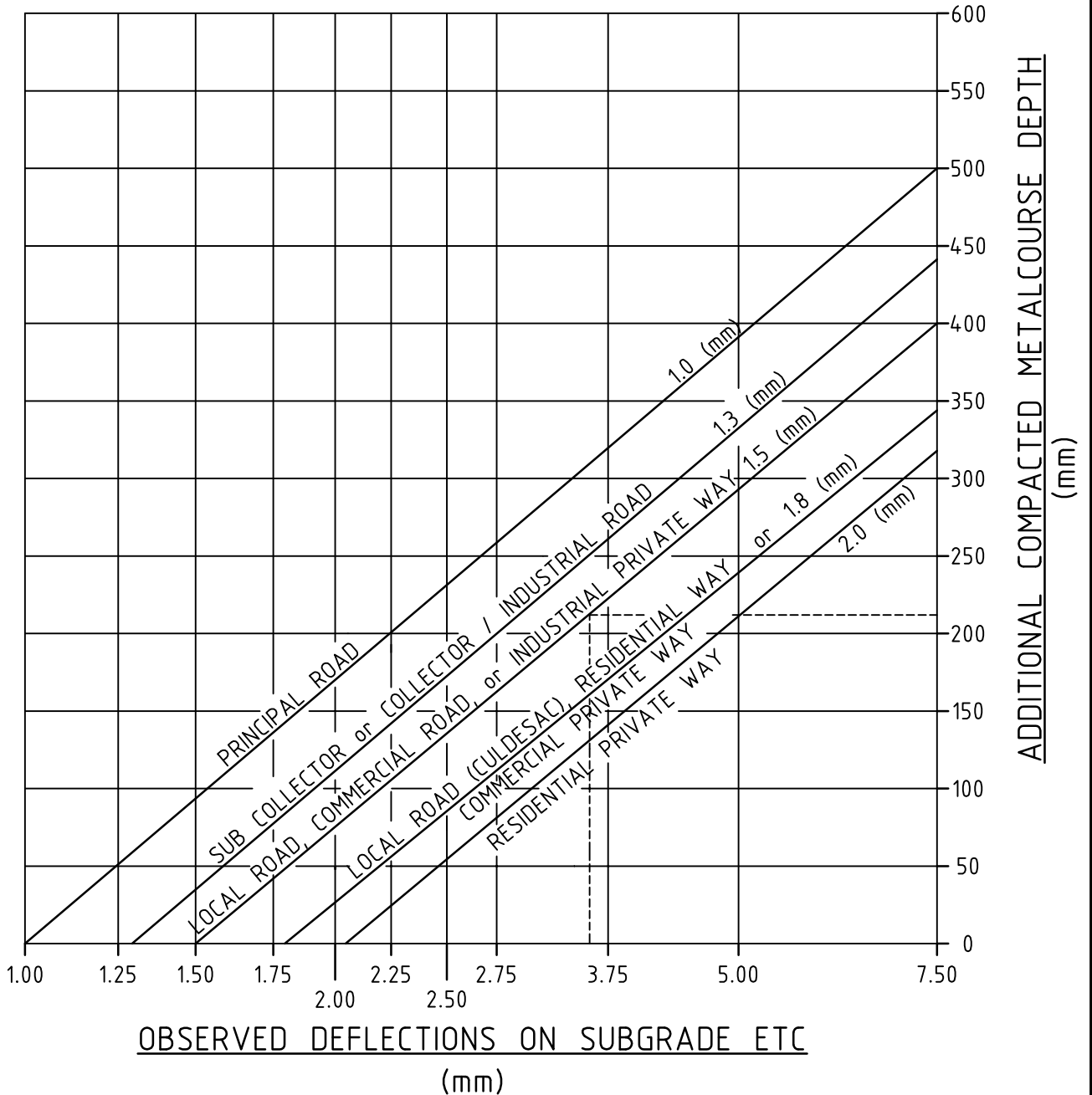

**NELSON  
CITY  
COUNCIL**

**DESIGN GRAPH FOR FLEXIBLE  
PAVEMENTS  
BENKLEMAN BEAM DEFLECTIONS**

**INFRASTRUCTURAL ASSETS**

APPROVED

SENIOR EXECUTIVE INFRASTRUCTURE

29/07/2010

DATE

**SD 404**

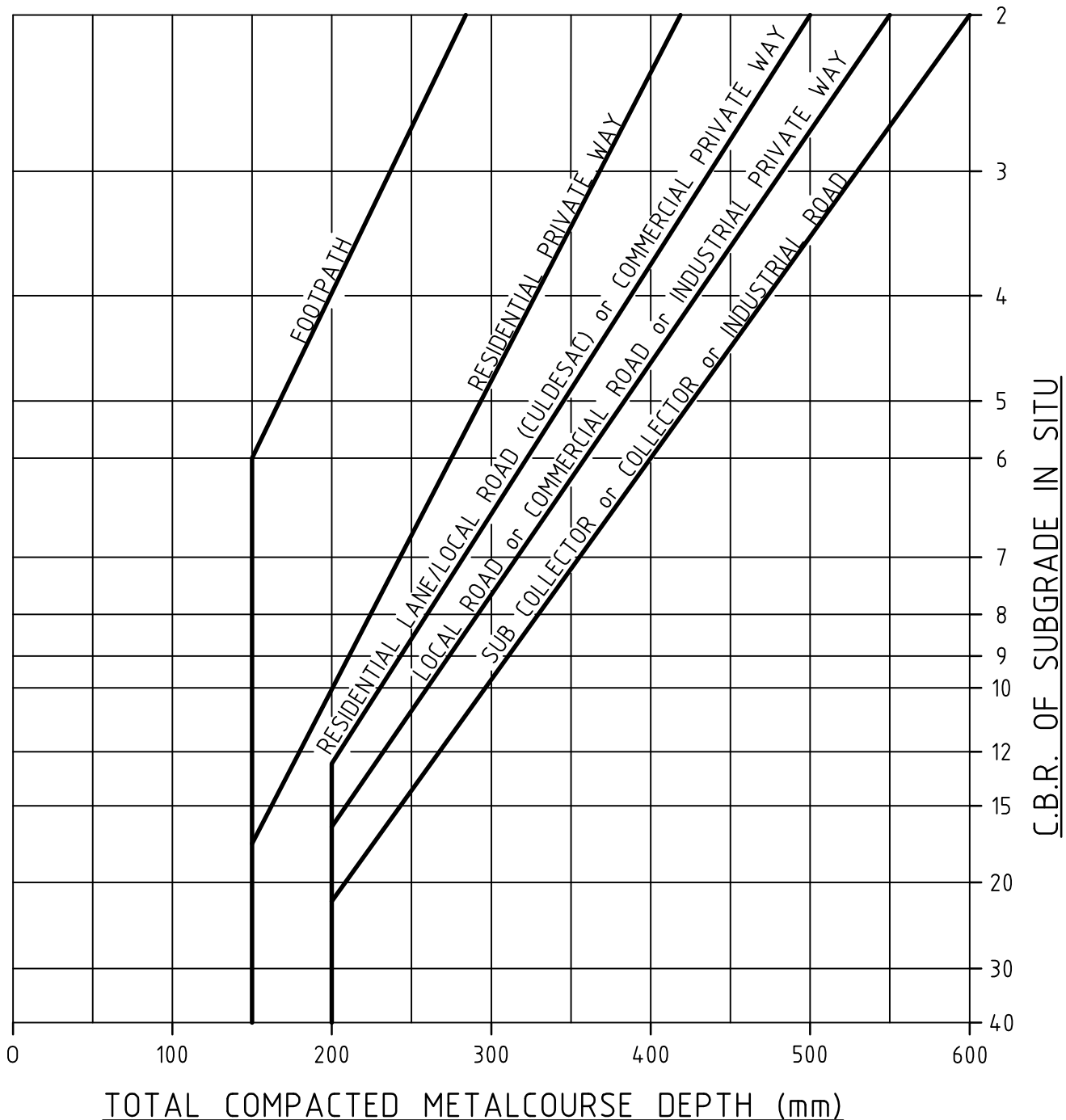

TOTAL COMPACTED METALCOURSE DEPTH (mm)

NOTE: MINIMUM M/4 AP40 BASECOURSE LAYER REQUIRED IS 100mm FOR CONCRETE FOOTPATHS, 150mm FOR ASPHALTIC CONCRETE FOOTPATHS & RESIDENTIAL PRIVATE WAY's, 200mm FOR ROADS & COMMERCIAL/INDUSTRIAL PRIVATE WAY's

**NELSON  
CITY  
COUNCIL**

**DESIGN GRAPH FOR FLEXIBLE  
PAVEMENTS CBR METHOD**

**INFRASTRUCTURAL ASSETS**  
 APPROVED   
 SENIOR EXECUTIVE INFRASTRUCTURE      29/07/2010  
 DATE

**SD 405**

BLOWS / 100mm PENETRATION

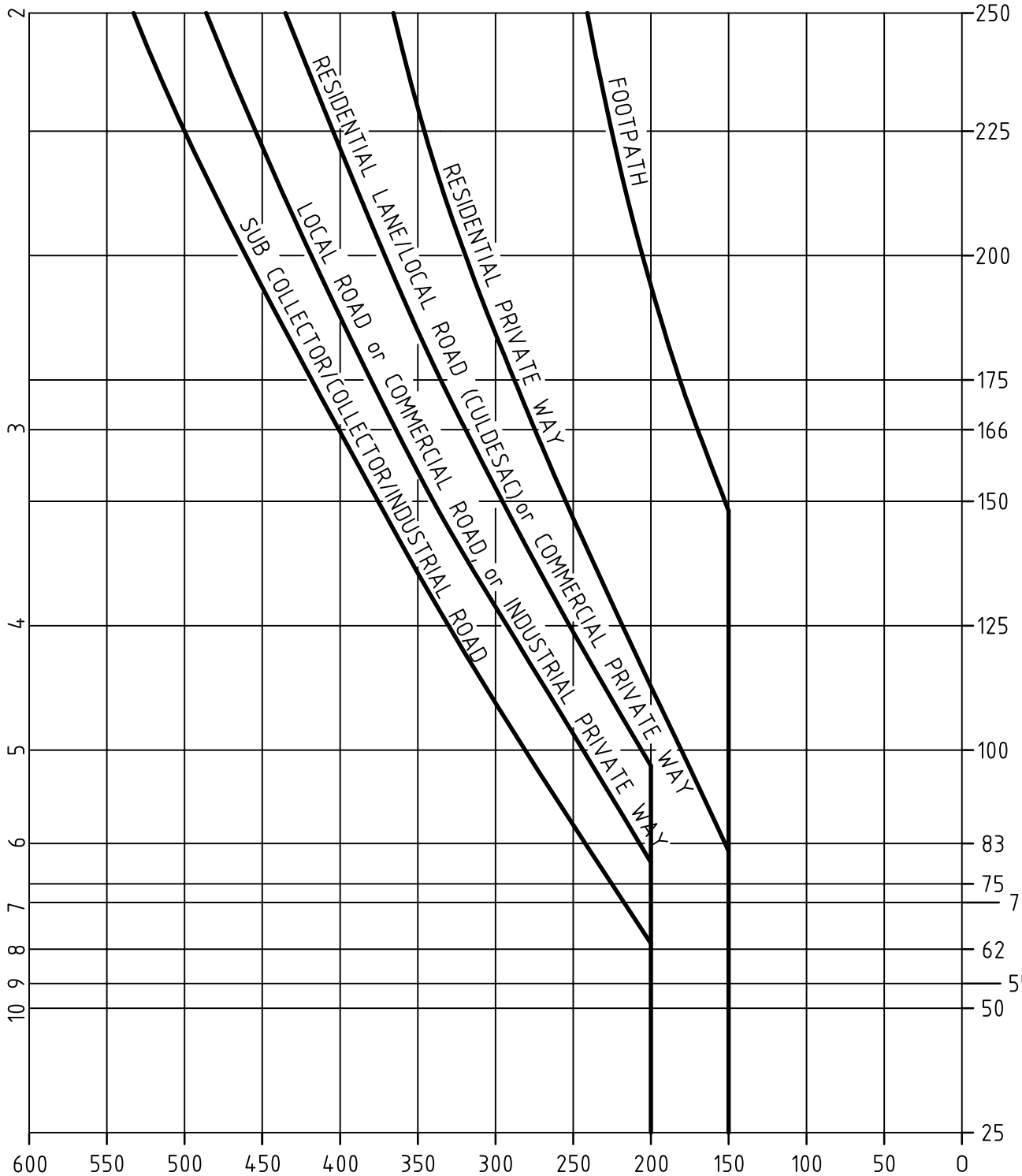

TOTAL COMPACTED METALCOURSE DEPTH

NOTE: MINIMUM M/4 AP40 BASECOURSE LAYER REQUIRED IS 100mm FOR CONCRETE FOOTPATHS, 150mm FOR ASPHALTIC CONCRETE FOOTPATHS & RESIDENTIAL PRIVATE WAY's, 200mm FOR ROADS & COMMERCIAL/INDUSTRIAL PRIVATE WAY's

**NELSON  
CITY  
COUNCIL**

**DESIGN GRAPH FOR FLEXIBLE PAVEMENTS  
SCALA DYNAMIC CONE PENETROMETER**

**INFRASTRUCTURAL ASSETS**

APPROVED

SENIOR EXECUTIVE INFRASTRUCTURE

29/07/2010

DATE

**SD 406**

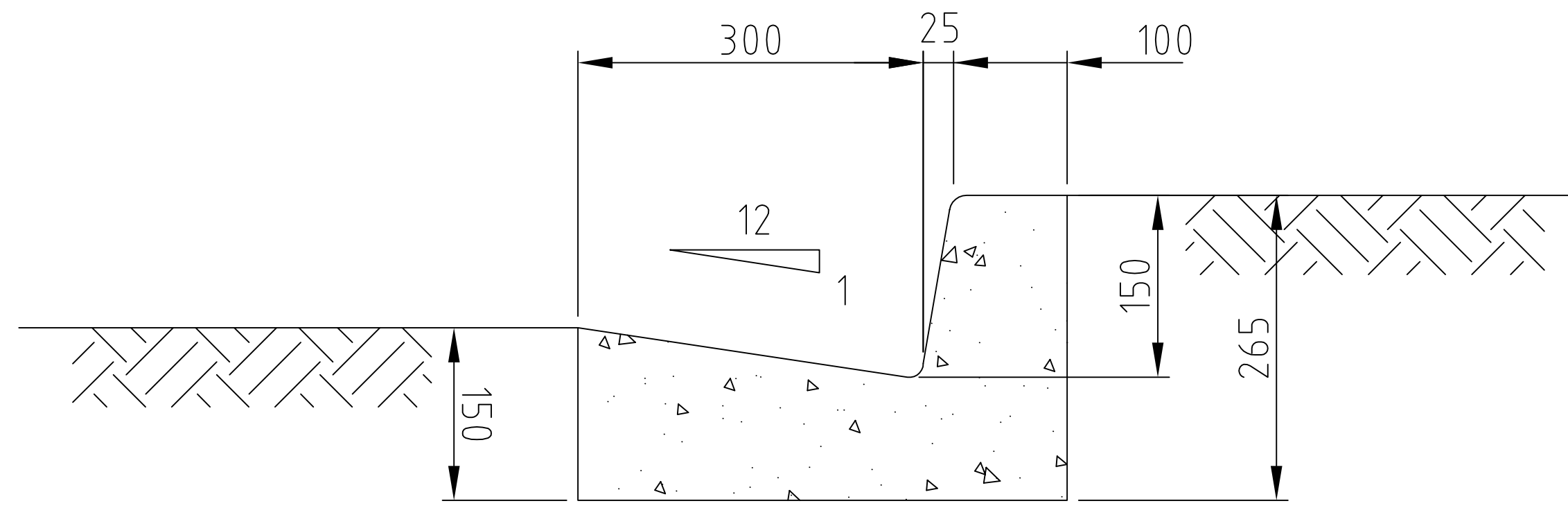

KERB & CHANNEL

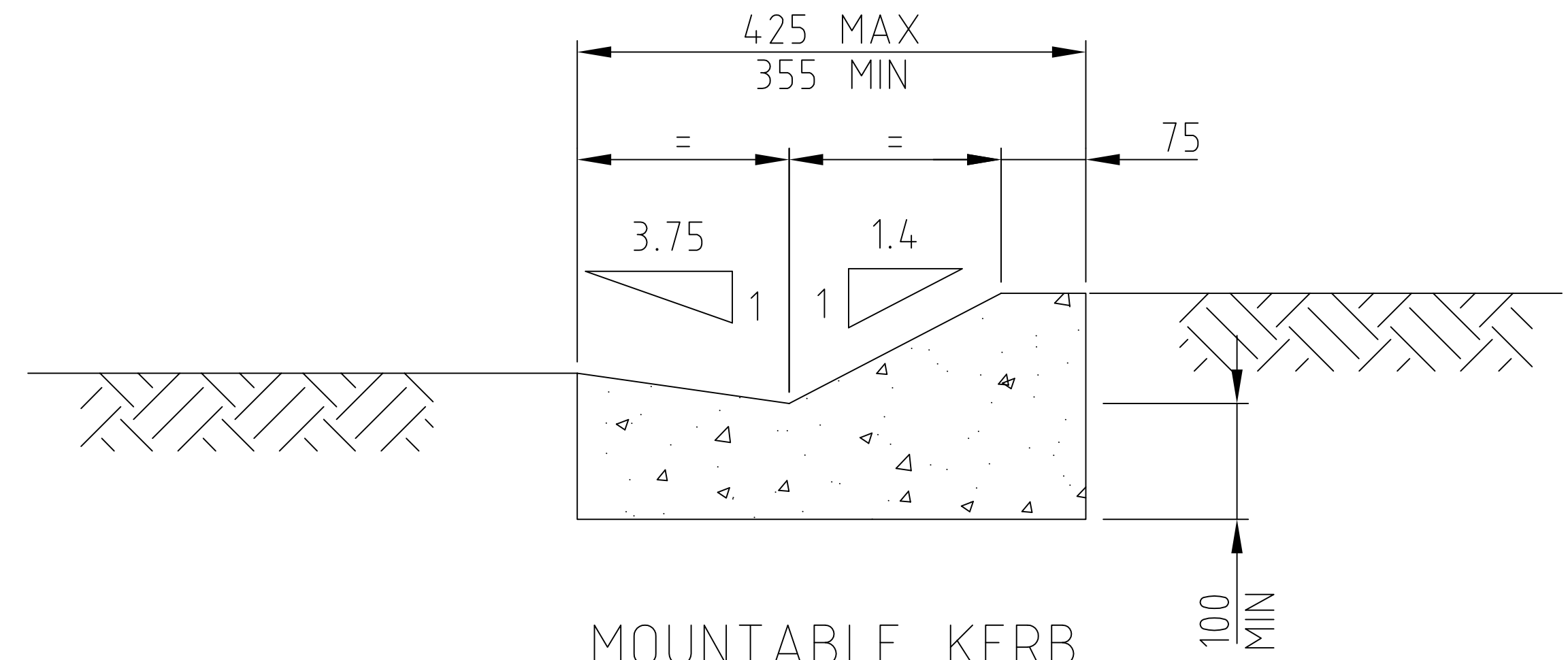

MOUNTABLE KERB & CHANNEL

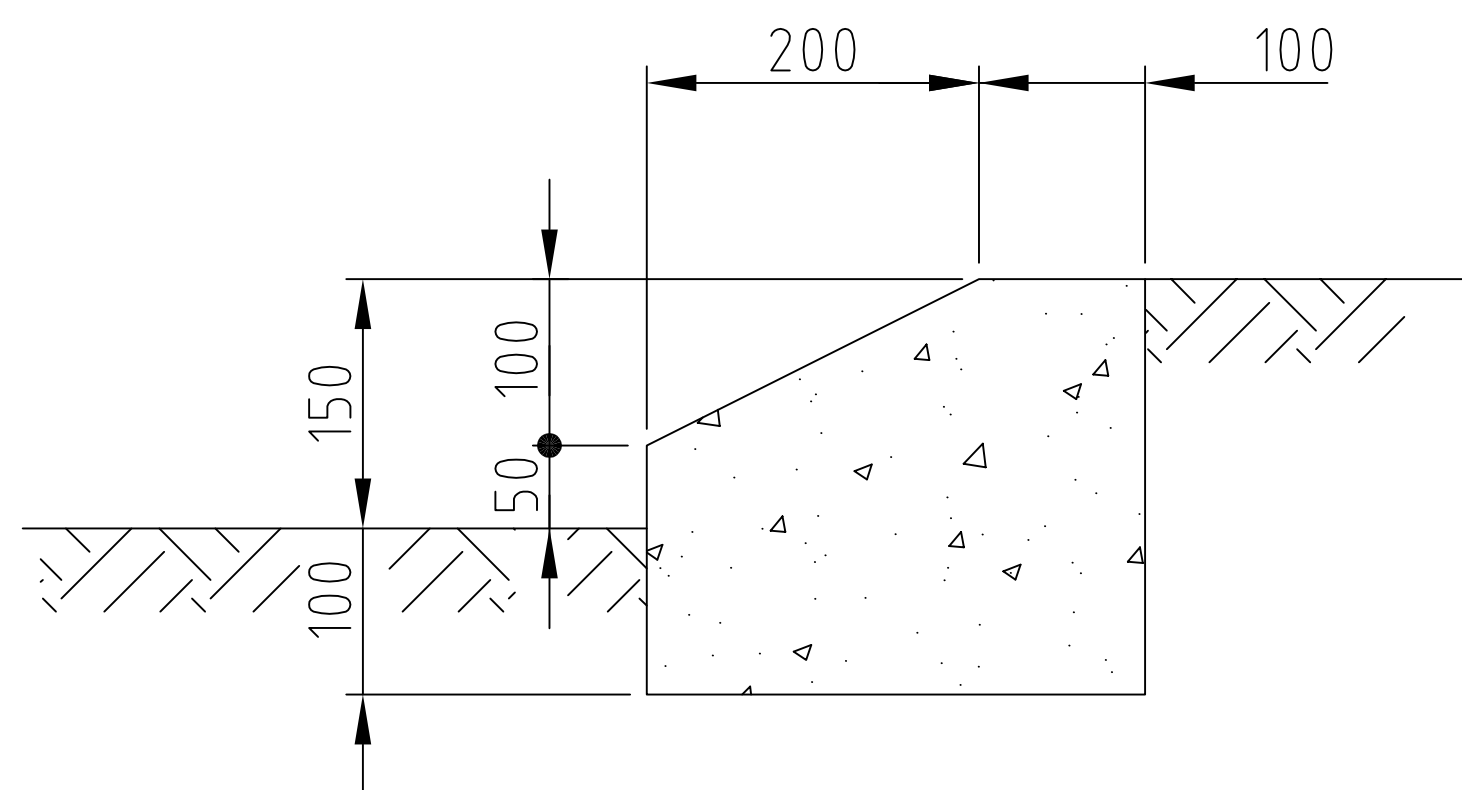

MOUNTABLE KERB

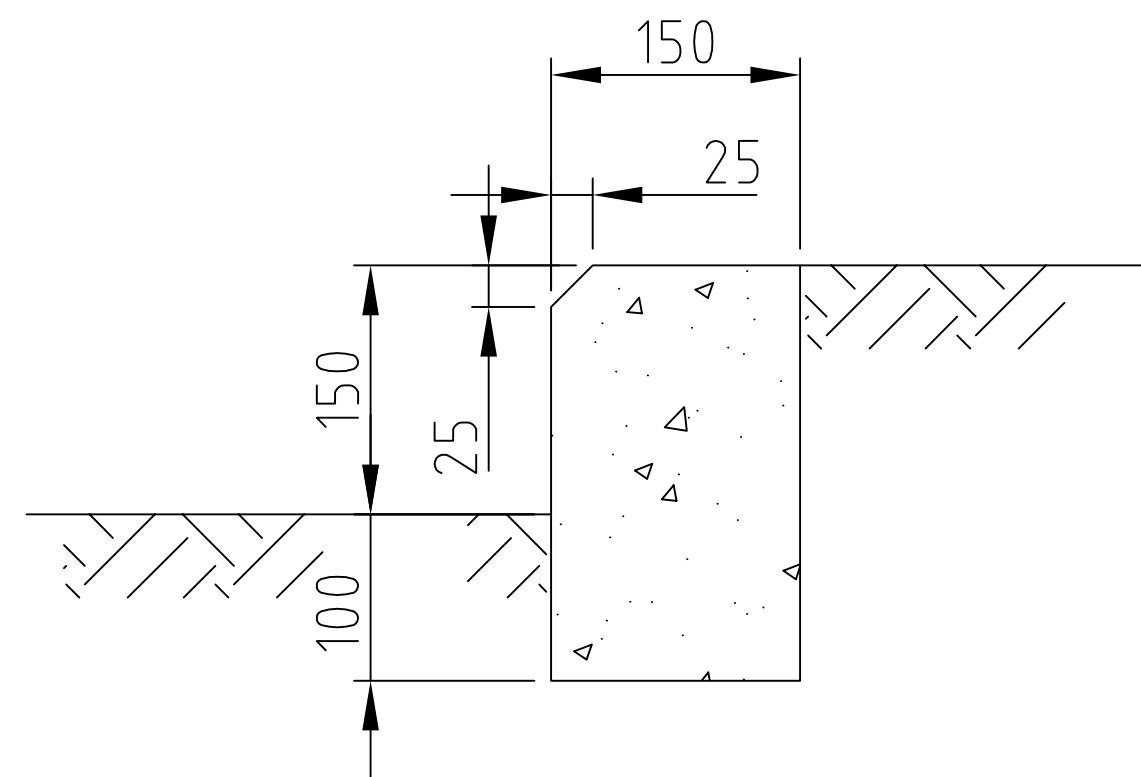

UNMOUNTABLE KERB

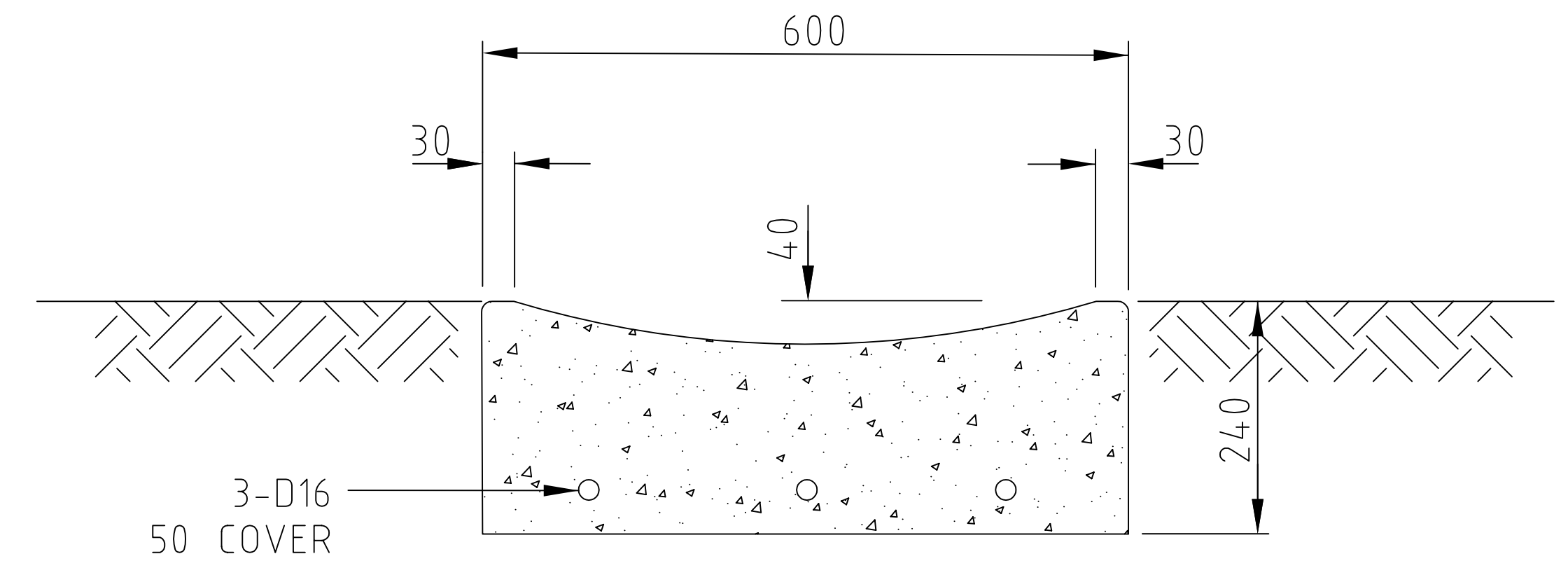

DISH CHANNEL

**NELSON  
CITY  
COUNCIL**

STANDARD KERB & CHANNEL  
PROFILES

**INFRASTRUCTURAL ASSETS**

APPROVED

29/07/2010

SENIOR EXECUTIVE INFRASTRUCTURE

DATE

**SD 407**

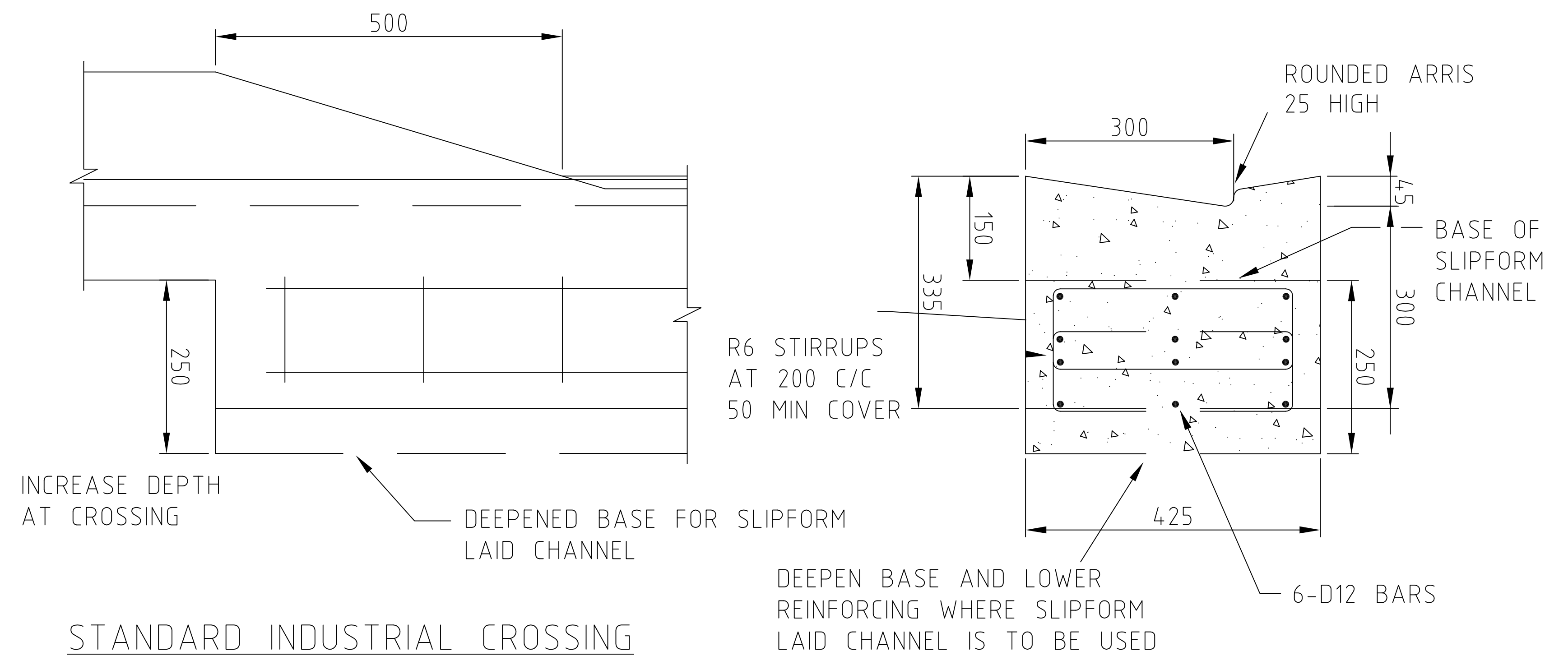
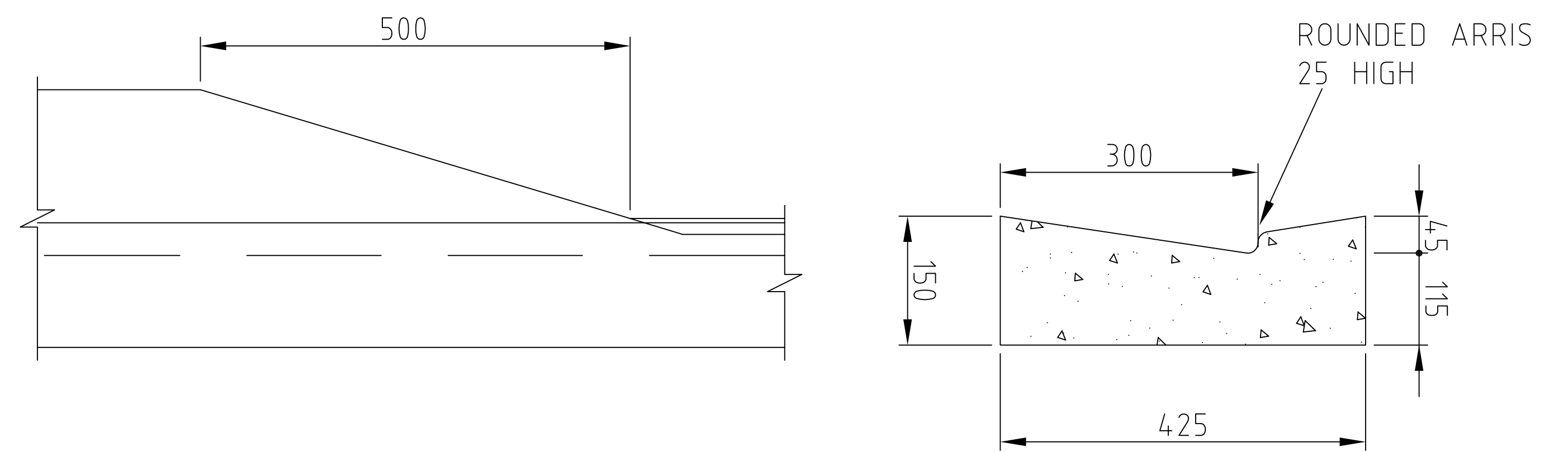
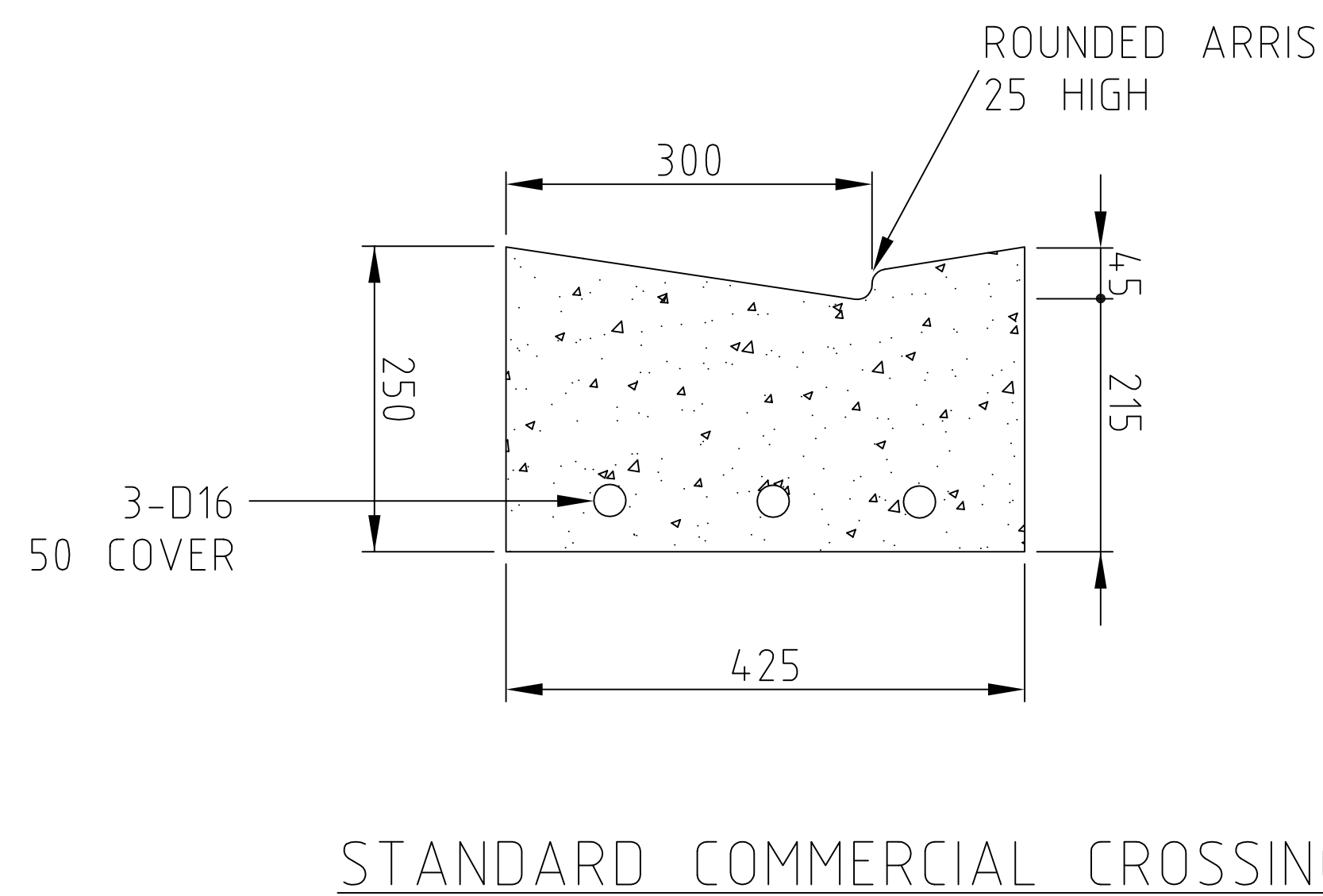
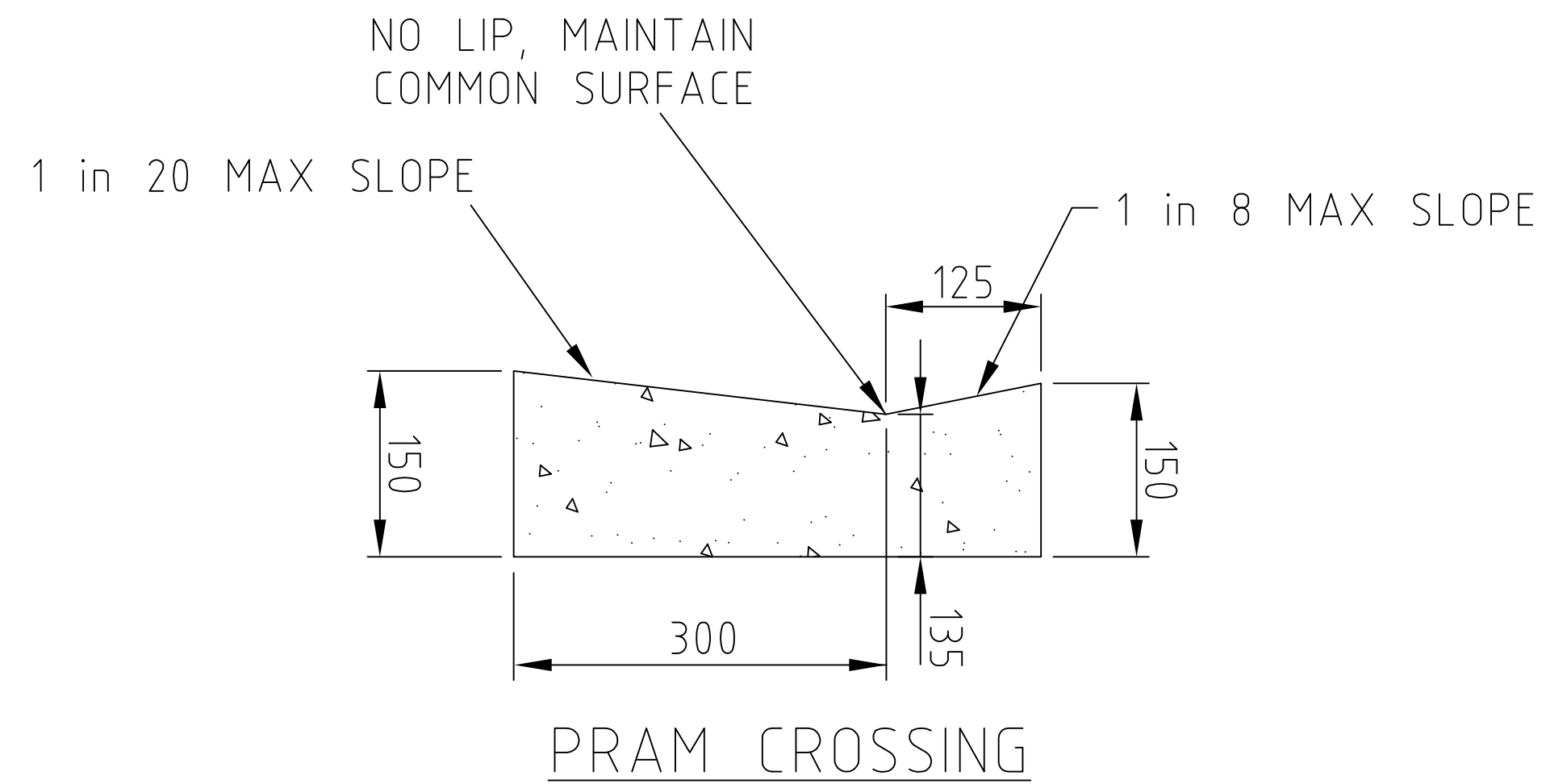
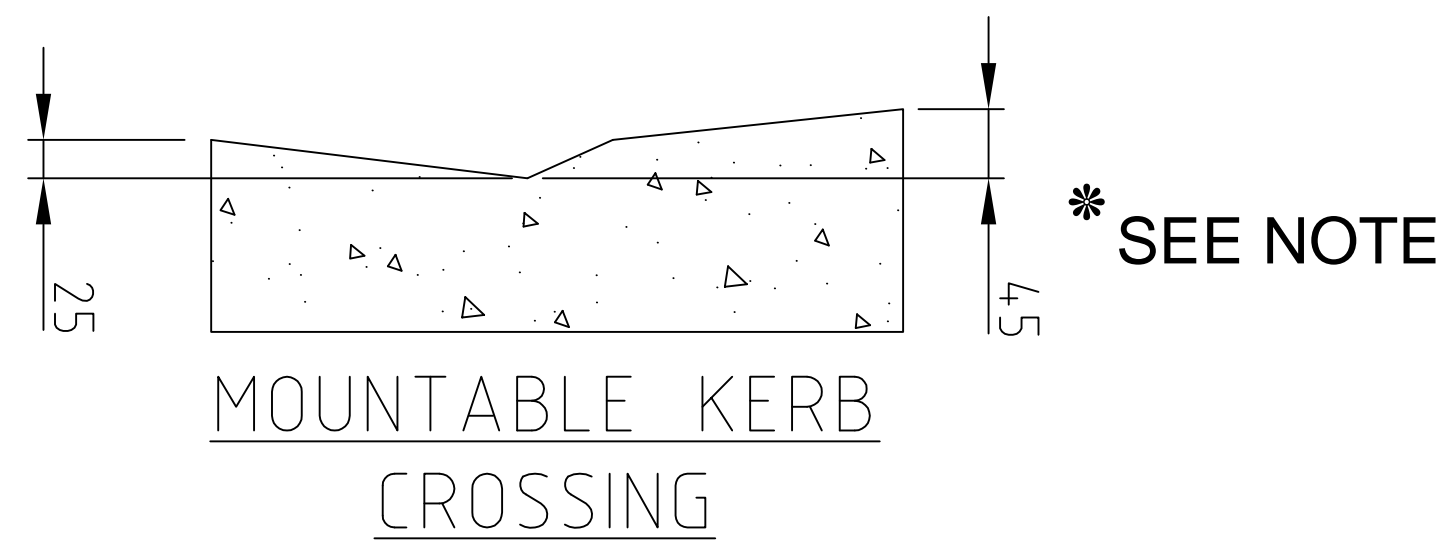

\* NOTE:  
FOR LOCAL ROADS WHERE THE VEHICLE DESIGN SPEED IS 40km/hr or LESS, AND THE FOOTPATH IS ADJACENT THE KERB, THEN FULL HEIGHT MOUNTABLE KERB MUST BE USED

**NELSON CITY COUNCIL**

STANDARD KERB & CHANNEL CROSSINGS

**INFRASTRUCTURAL ASSETS**

APPROVED

29/07/2010

SENIOR EXECUTIVE INFRASTRUCTURE

DATE

**SD 408**



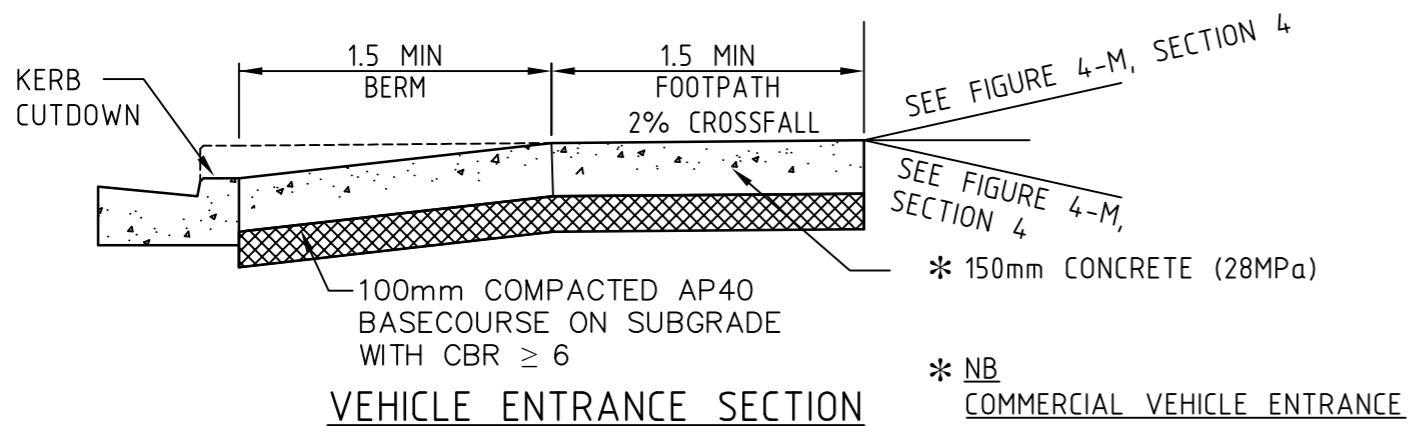
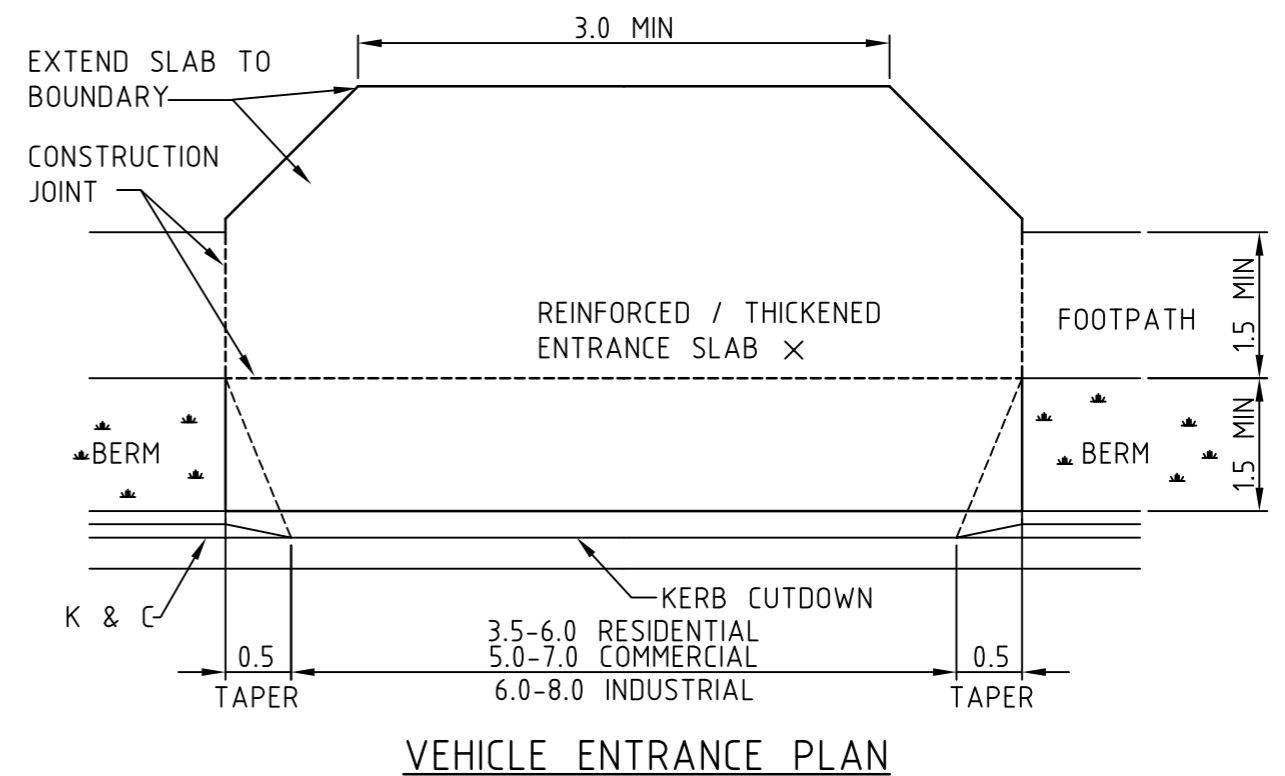
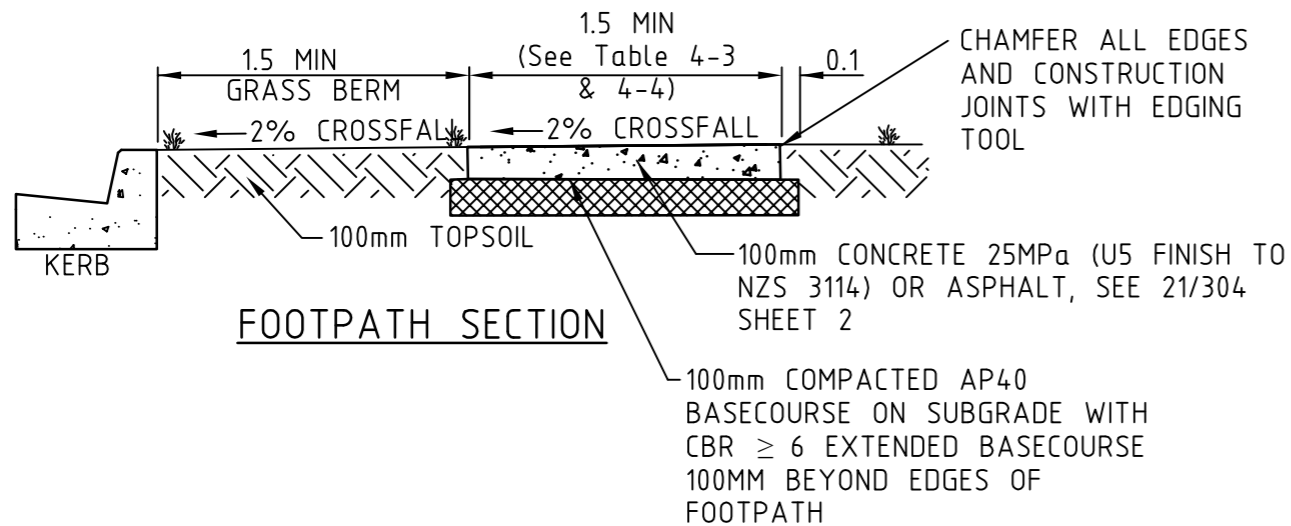

\* NB  
COMMERCIAL VEHICLE ENTRANCE  
 200mm DEPTH CONCRETE, 30MPa  
 REINFORCED WITH ONE LAYER  
 665 WWF WITH 50mm COVER  
 FROM UNDERSIDE OF CONCRETE  
 SURFACE.

INDUSTRIAL VEHICLE ENTRANCE  
 300mm THICK CONCRETE, 30MPa  
 WITH 2 LAYERS OF 665 WWF  
 REINFORCING. WWF SHALL HAVE  
 200mm SEPERATION AND 50mm  
 COVER.

<b>NELSON CITY COUNCIL</b>	<b>1.5m WIDE FOOTPATH OFFSET FROM KERB</b>	
	<b>INFRASTRUCTURAL ASSETS</b> APPROVED  29/07/2010 SENIOR EXECUTIVE INFRASTRUCTURE DATE	<b>SD 409</b>

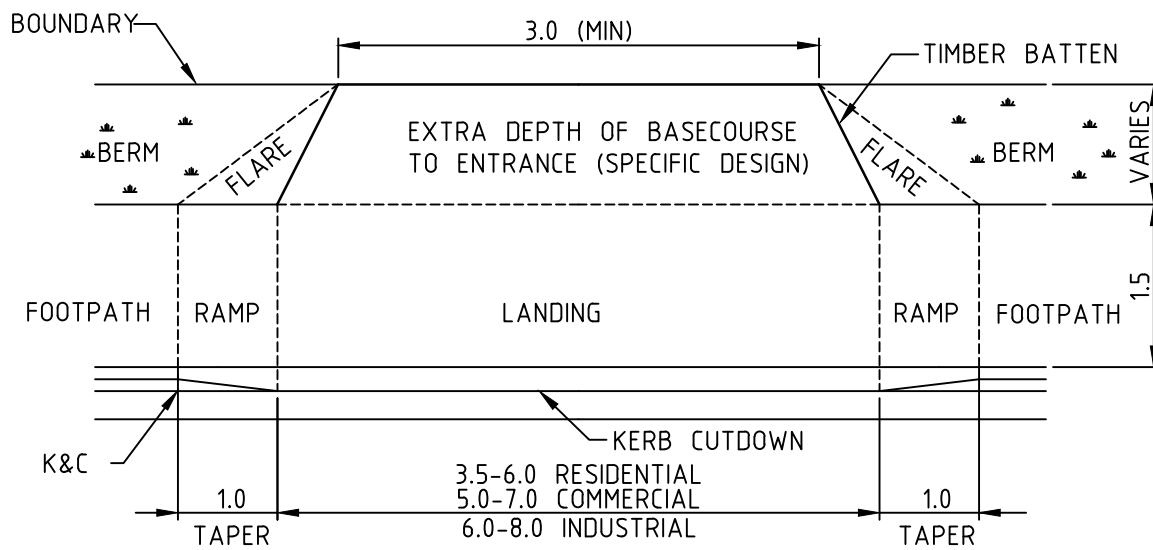
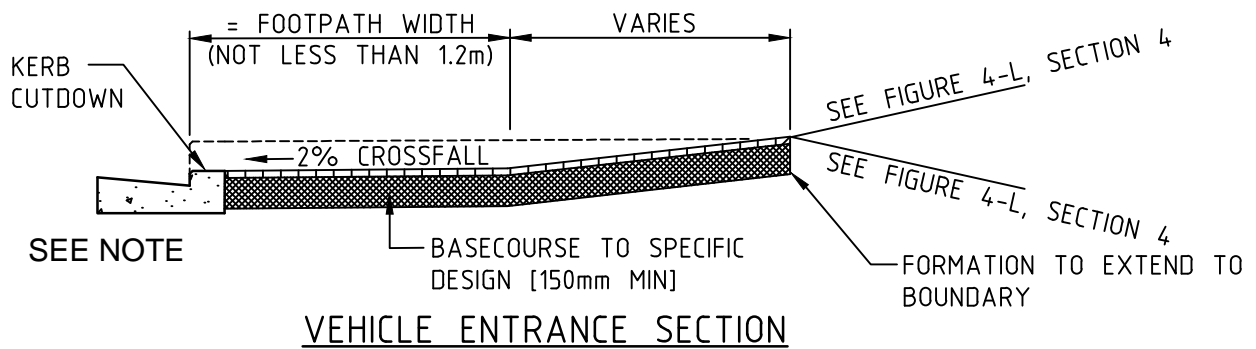
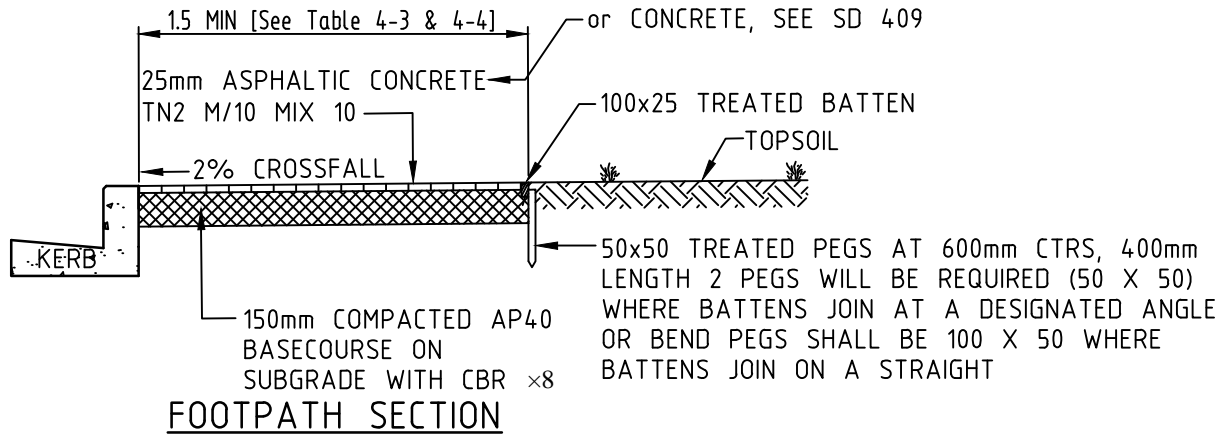

**NOTE:**

1. FOR LOCAL ROADS WHERE THE VEHICLE DESIGN SPEED IS 40km/hr or LESS, AND THE FOOTPATH IS ADJACENT THE KERB, THEN FULL HEIGHT MOUNTABLE KERB & CHANNEL MUST BE USED
2. VEHICLE ENTRANCE & FOOTPATH TRANSITION MUST COMPLY WITH FIGURE 15.1 & TABLE 15.2 OF THE LAND TRANSPORT NZ 'PEDESTRIAN PLANNING & DESIGN GUIDE

**NELSON  
CITY  
COUNCIL**

**1.5m WIDE FOOTPATH  
ADJACENT KERB**

**INFRASTRUCTURAL ASSETS**

APPROVED

29/07/2010

SENIOR EXECUTIVE INFRASTRUCTURE

DATE

**SD 410**

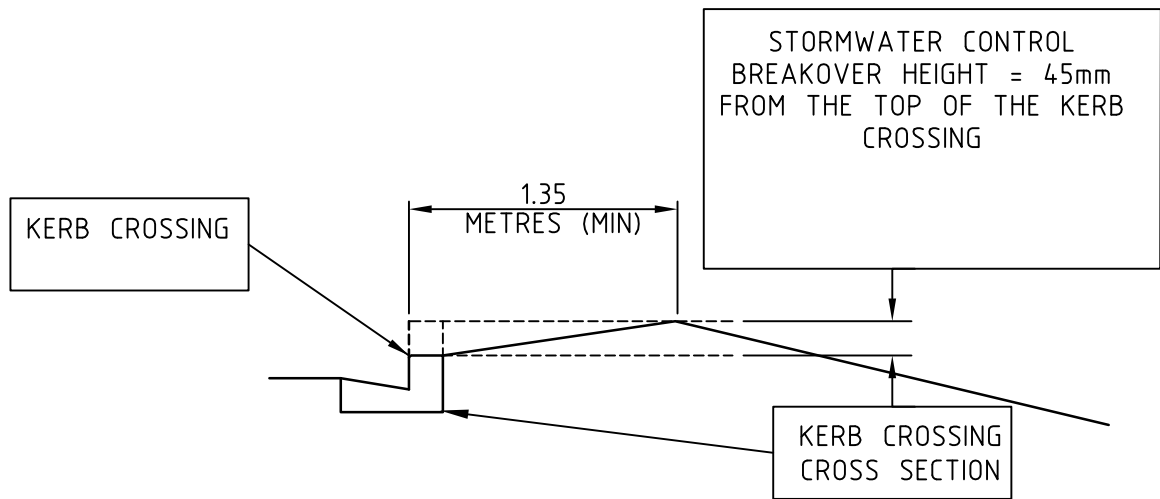

DIMENSIONS OF STORMWATER BREAKOVER CONTROL FOR ACCESSES BELOW THE ROAD

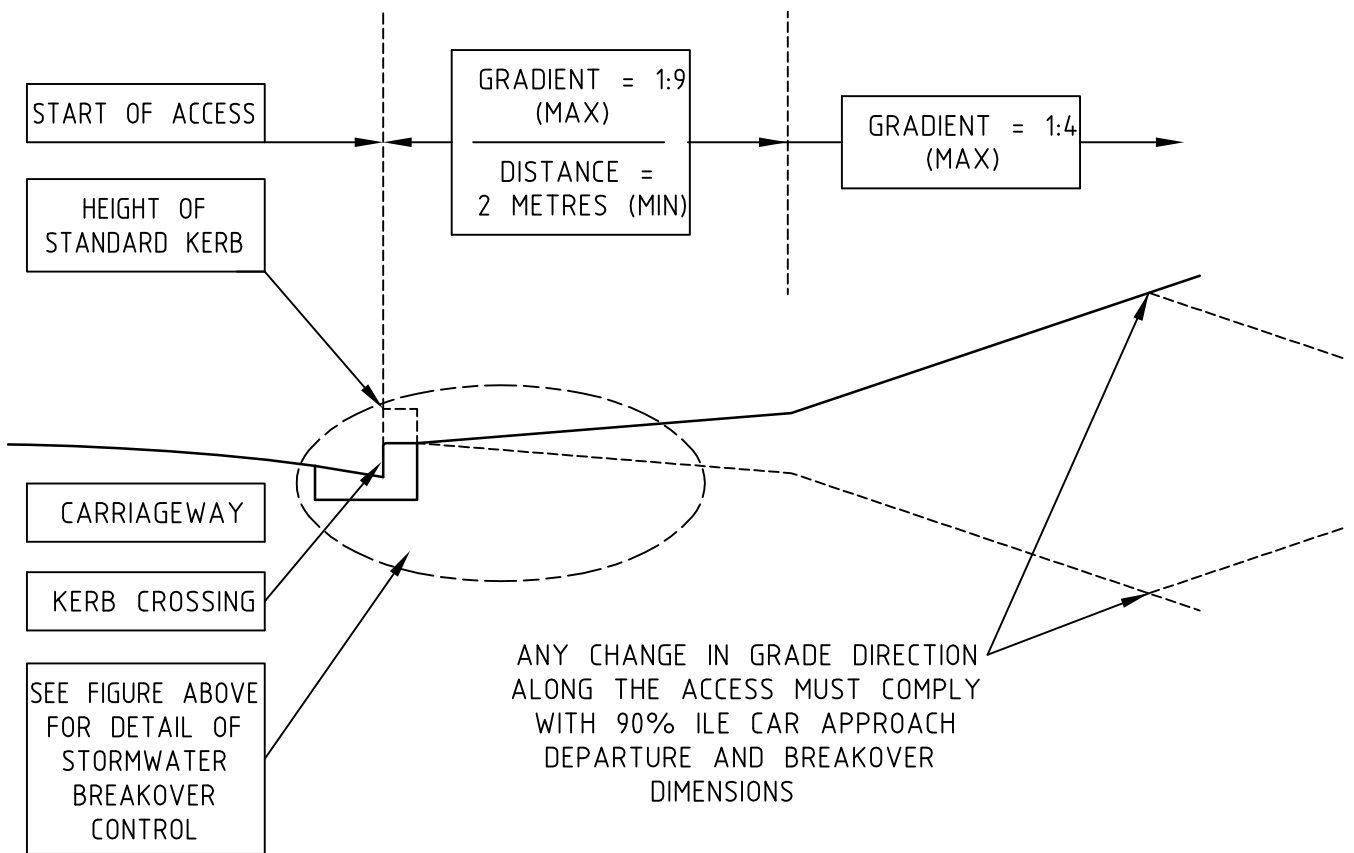

GRADIENT OF ACCESS AND BREAKOVER ANGLES FOR ACCESS TO SITES WHERE THERE IS NO EXISTING OR PROPOSED FOOTPATH

**NELSON  
CITY  
COUNCIL**

**ACCESS BREAKOVER ANGLES WHERE  
NO PROPOSED FOOTPATH**

**INFRASTRUCTURAL ASSETS**

APPROVED

.....  
SENIOR EXECUTIVE INFRASTRUCTURE

29/07/2010

.....  
DATE

**SD 411**

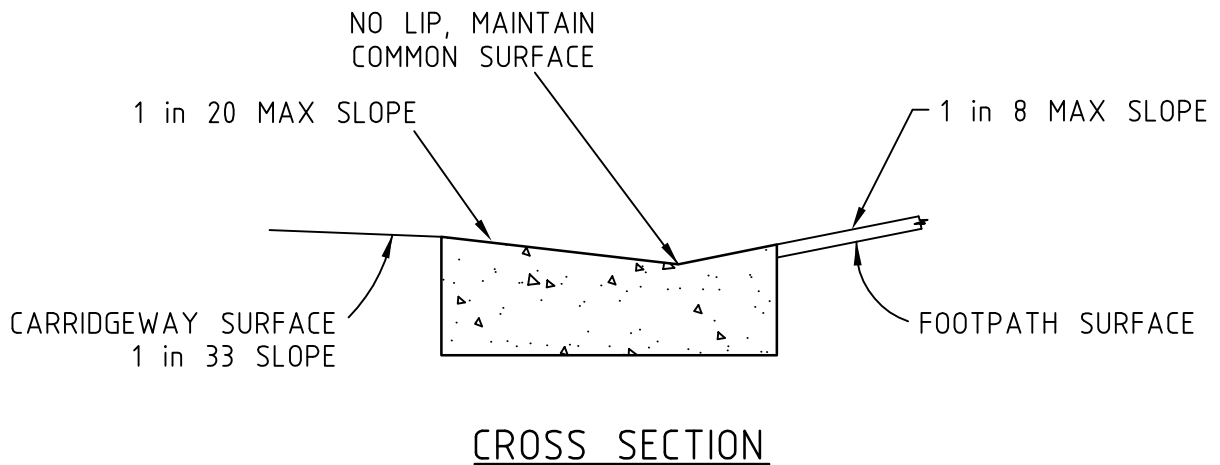
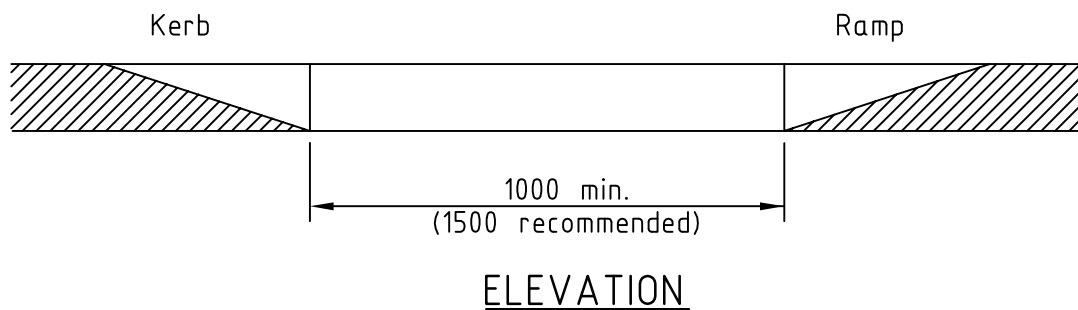
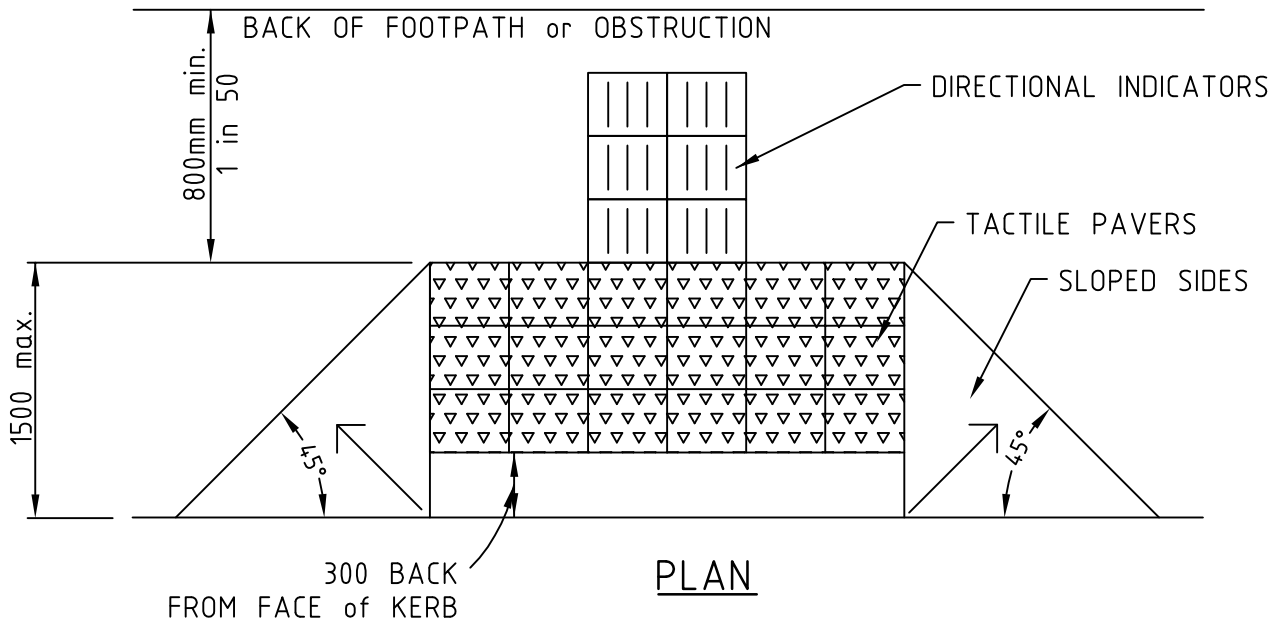

NOTE: FOR LAYOUT and INSTALLATION OF TACTILE PAVING & DIRECTIONAL INDICATORS, SEE SECTION 4.3.12.8

**NELSON  
CITY  
COUNCIL**

**PEDESTRIAN KERB CROSSING  
AND RAMP**

**INFRASTRUCTURAL ASSETS**

APPROVED

.....  
SENIOR EXECUTIVE INFRASTRUCTURE

29/07/2010

.....  
DATE

**SD 412**

WIDTH VARIES ACCORDING TO ROAD TYPE  
(SEE TABLE 4-3 & 4-4)

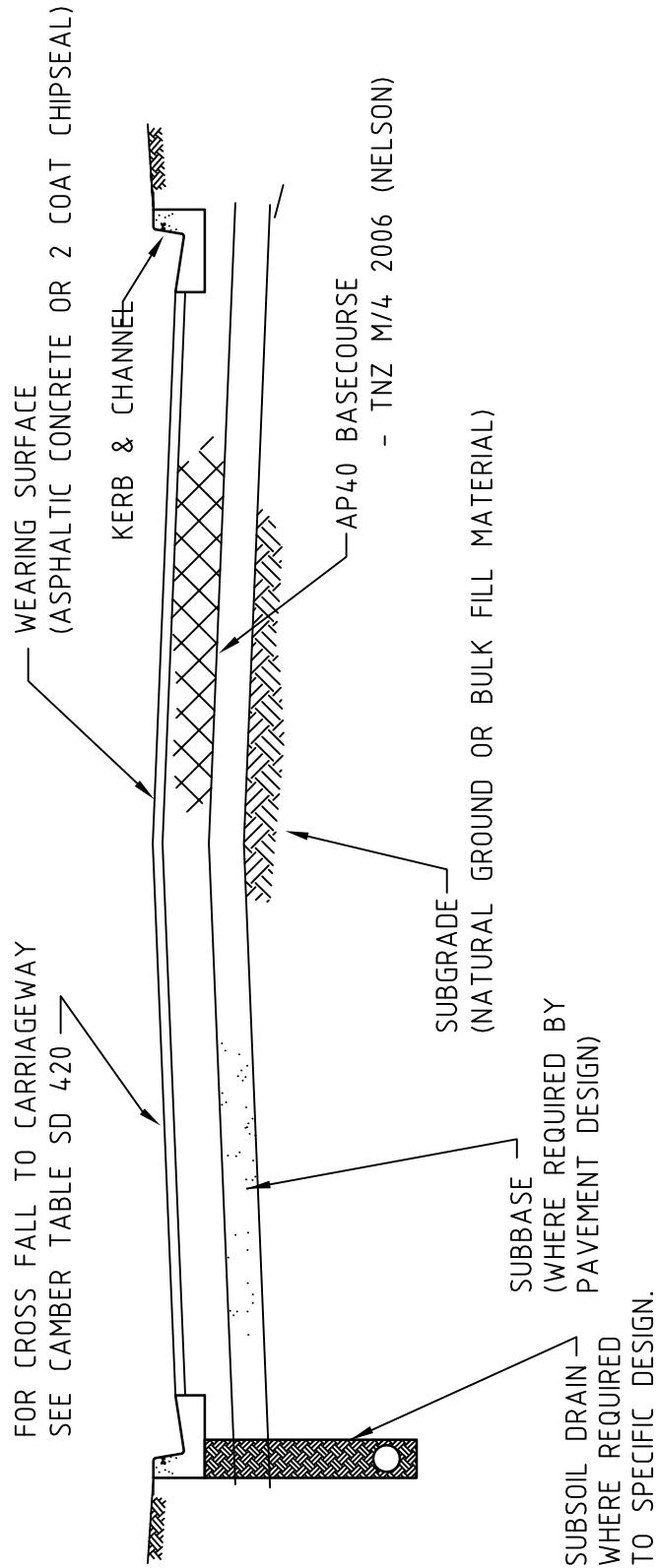

DEPTHS OF BASECOURSE AND SUBBASE  
(WHERE REQUIRED) TO BE AS DETAILED IN  
SPECIFIC PAVEMENT DESIGN FOR EACH  
INDIVIDUAL STREET

**NELSON  
CITY  
COUNCIL**

**TYPICAL CROSS SECTION  
CARRIAGEWAY**

**INFRASTRUCTURAL ASSETS**

APPROVED

.....  
SENIOR EXECUTIVE INFRASTRUCTURE

29/07/2010

.....  
DATE

**SD 413**

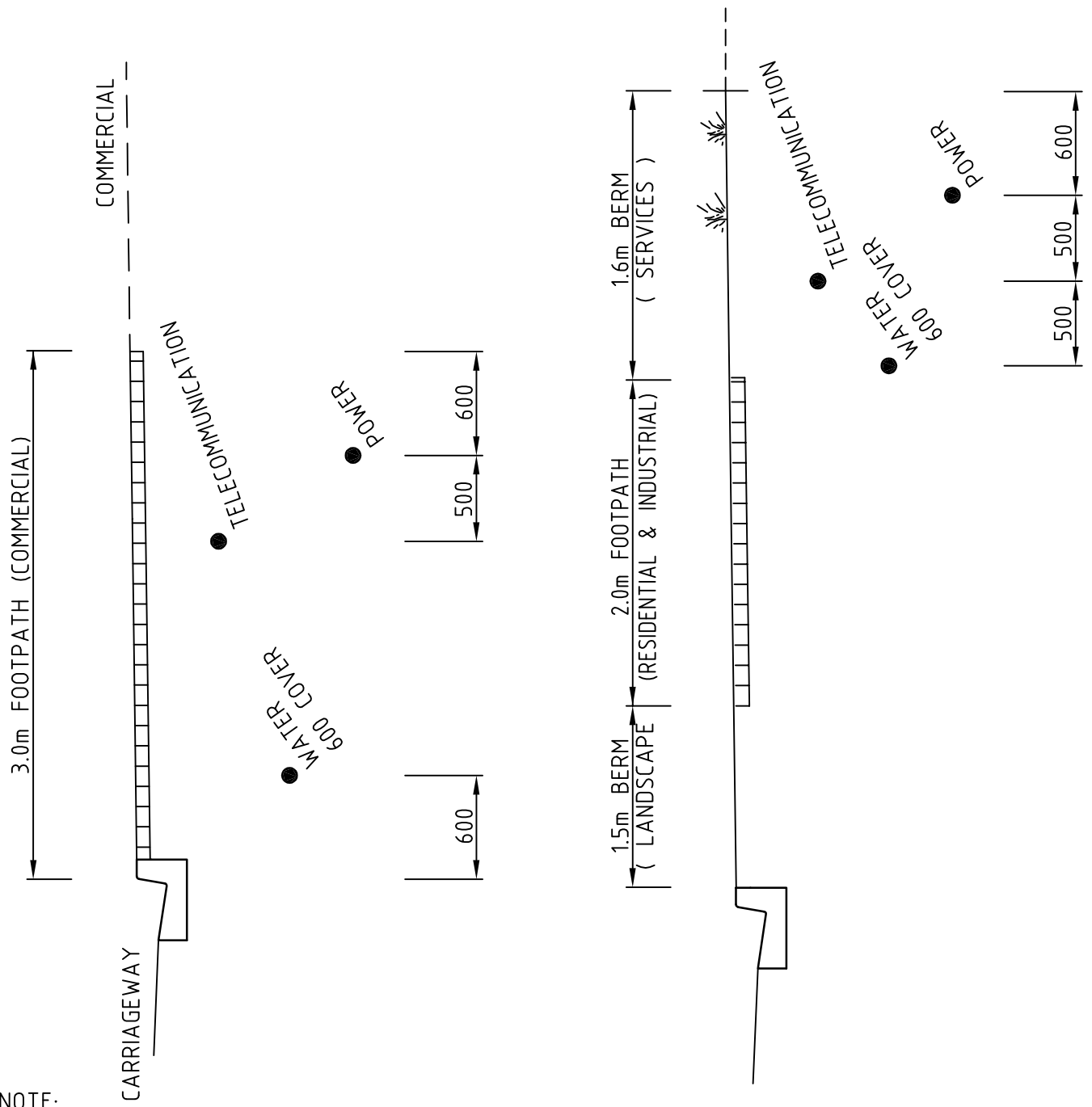

**NOTE:**

1. SERVICES BERM CAN BE REDUCED TO 0.5m WHERE SERVICES ARE UNDER THE FOOTPATH PROVIDED THEY DO NOT PRECLUDE THE INTRODUCTION OF STREET TREES
2. THE DEPTH OF CABLES MAY VARY. SEE SECTION 10 FOR POWER, & SECTION 11 FOR COMMUNICATION CABLE RETICULATION
3. SEE SECTION 4.4.15.3 REGARDING ALTERNATIVE OPTIONS TO GRASS SURFACES & PLANTING WITHIN LANDSCAPE AREAS

**NELSON  
CITY  
COUNCIL**

**TYPICAL CROSS SECTIONS (BERMS)  
ARTERIAL & PRINCIPAL ROADS**

**INFRASTRUCTURAL ASSETS**

APPROVED

SENIOR EXECUTIVE INFRASTRUCTURE

29/07/2010

DATE

**SD 414**

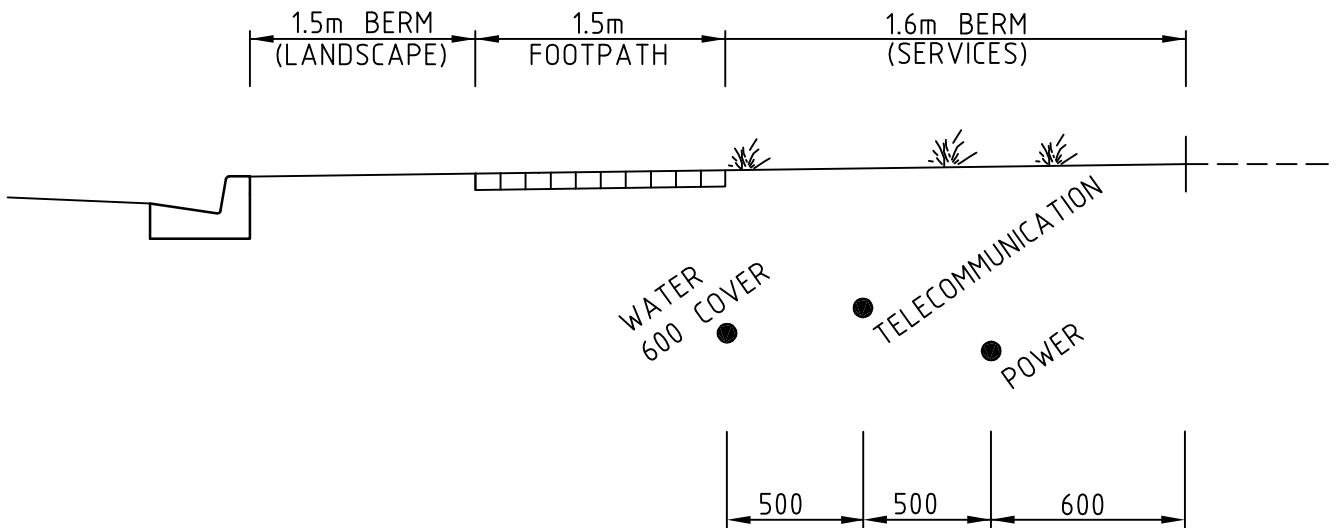

NOTE:

1. SERVICES BERM CAN BE REDUCED TO 0.5m WHERE SERVICES ARE LOCATED UNDER THE FOOTPATH PROVIDED THEY DO NOT PRECLUDE THE INTRODUCTION OF STREET TREES
2. THE DEPTH OF CABLES MAY VARY. SEE SECTION 10 FOR POWER, & SECTION 11 FOR COMMUNICATION CABLE RETICULATION
3. SEE SECTION 4.4.15.3 REGARDING ALTERNATIVE OPTIONS TO GRASS SURFACES & PLANTING WITHIN LANDSCAPE AREAS

<b>NELSON CITY COUNCIL</b>	<b>TYPICAL CROSS SECTIONS (BERMS) COLLECTOR, SUB COLLECTOR &amp; LOCAL ROADS</b>	
	<b>INFRASTRUCTURAL ASSETS</b> APPROVED  SENIOR EXECUTIVE INFRASTRUCTURE	29/07/2010 DATE

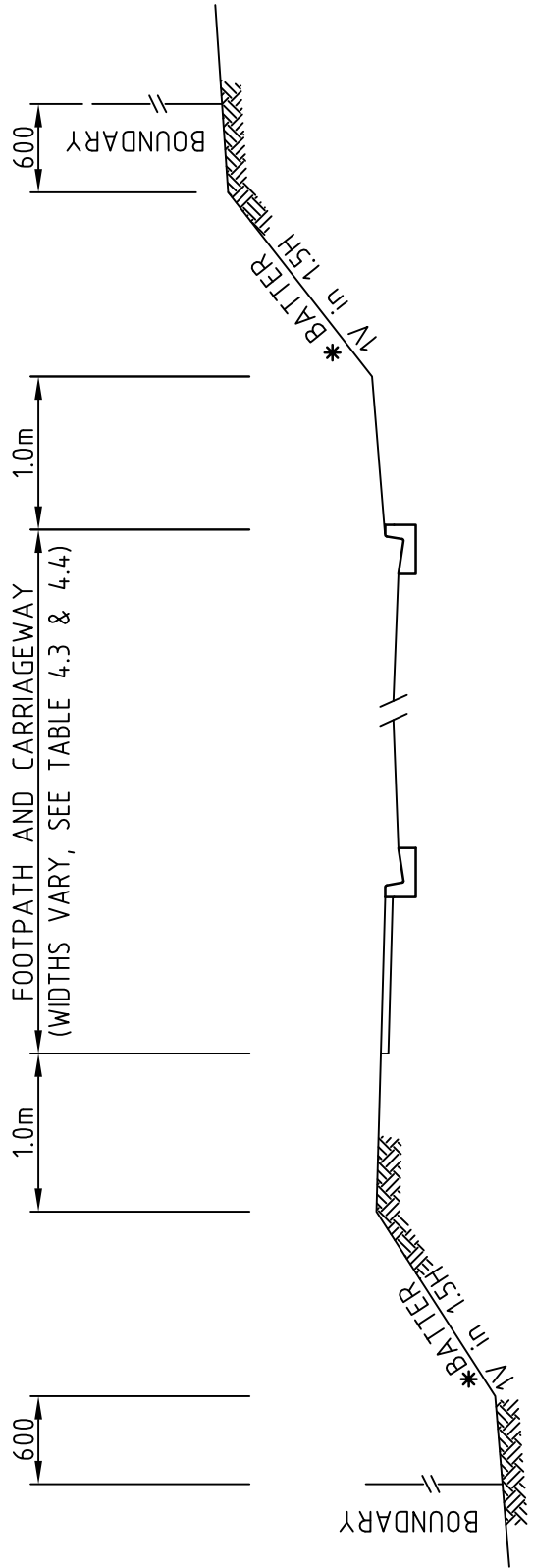

**\* NOTES:**

BATTER SLOPES MAY BE REPLACED BY RETAINING WALLS TO SPECIFIC DESIGN WHERE APPROVED BY THE COUNCIL. RETAINING WALLS WHICH ARE NOT FOR SUPPORTING THE ROAD CARRIAGEWAY or FOOTPATH MUST BE LOCATED OUTSIDE LEGAL ROAD RESERVE

THE 1.0m DISTANCE FROM BACK OF FOOTPATH/KERB MAY BE INCREASED WHERE THE AREA IS REQUIRED AS SERVICE STRIPS BY TABLE 4.3 & 4.4

**NELSON  
CITY  
COUNCIL**

**TYPICAL CROSS SECTIONS ROADSIDE  
BATTERS**

**INFRASTRUCTURAL ASSETS**

APPROVED  29/07/2010

.....  
SENIOR EXECUTIVE INFRASTRUCTURE DATE

**SD 416**



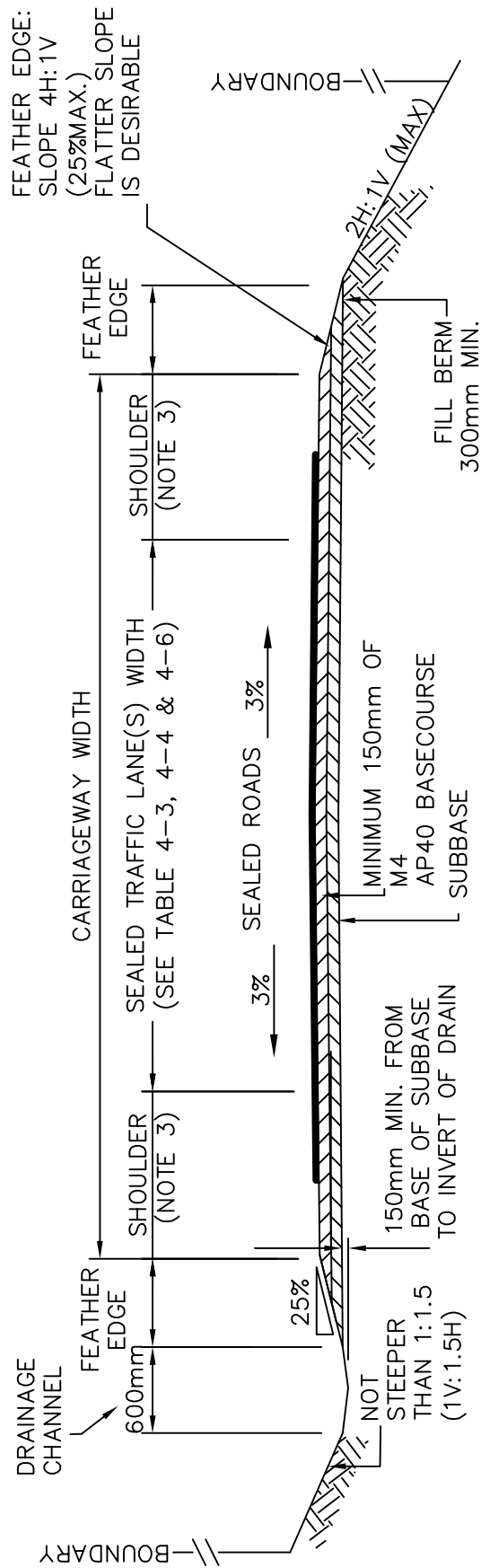

**NOTE: -**

1. DEPTH OF SUBBASE DETERMINED BY INDIVIDUAL PAVEMENT DESIGN FOR EACH STREET/ROAD
2. DRAINAGE CHANNEL SIZE AND SPACING OF STORMWATER CULVERTS, SUBJECT TO SPECIFIC DESIGN.
3. FOR SHOULDER WIDTHS, SEE TABLE 4-5, SECTION 4 OF THE LAND DEVELOPMENT MANUAL

**NELSON  
CITY  
COUNCIL**

**TYPICAL CROSS SECTIONS  
RURAL CARRIGEWAY**

**INFRASTRUCTURAL ASSETS**

APPROVED

.....  
SENIOR EXECUTIVE INFRASTRUCTURE

29/07/2010

.....  
DATE

**SD 417**

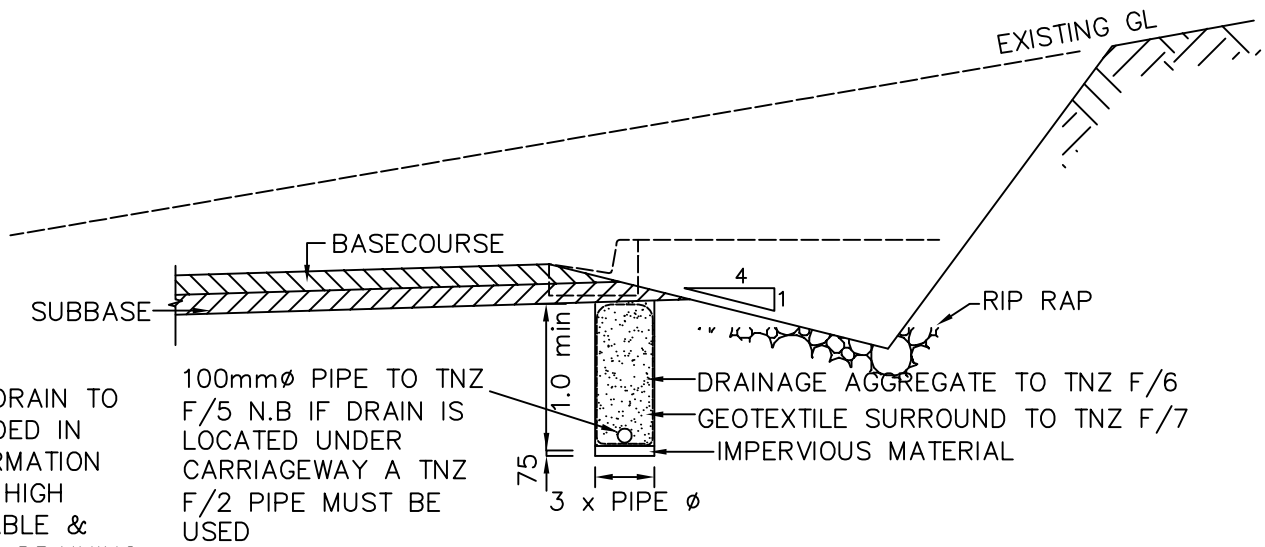

**NOTE:**  
 SUBSOIL DRAIN TO BE INCLUDED IN ROAD FORMATION WHERE A HIGH WATER TABLE & NON FREE DRAINING SUBGRADE MATERIALS EXIST

100mm $\phi$  PIPE TO TNZ F/5 N.B IF DRAIN IS LOCATED UNDER CARRIAGEWAY A TNZ F/2 PIPE MUST BE USED

**SUBSOIL DRAIN FILTER DETAIL (WHEN IN CUT)**

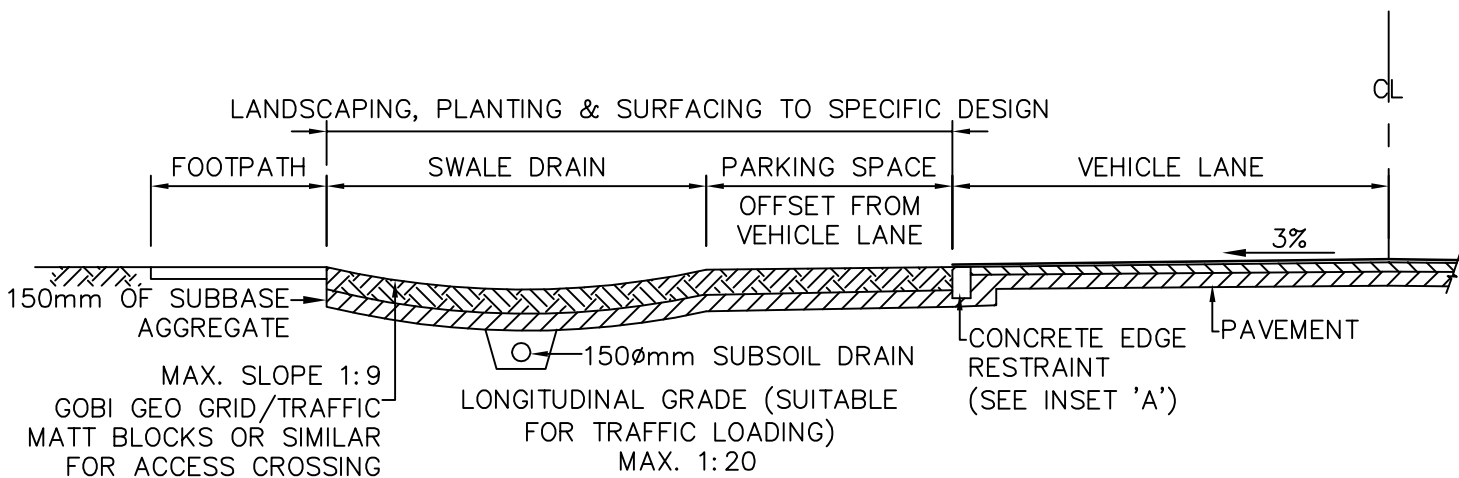

**ROADSIDE SWALE DRAINS – SUBJECT TO SITE CONDITIONS**

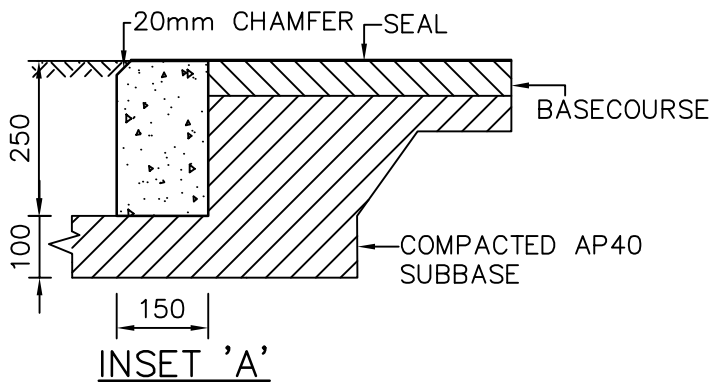

**NELSON CITY COUNCIL**

**TYPICAL DRAINAGE FOR ROADSIDE SWALES & LOW IMPACT STORMWATER**

**INFRASTRUCTURAL ASSETS**

APPROVED

29/07/2010

SENIOR EXECUTIVE INFRASTRUCTURE

DATE

**SD 418**

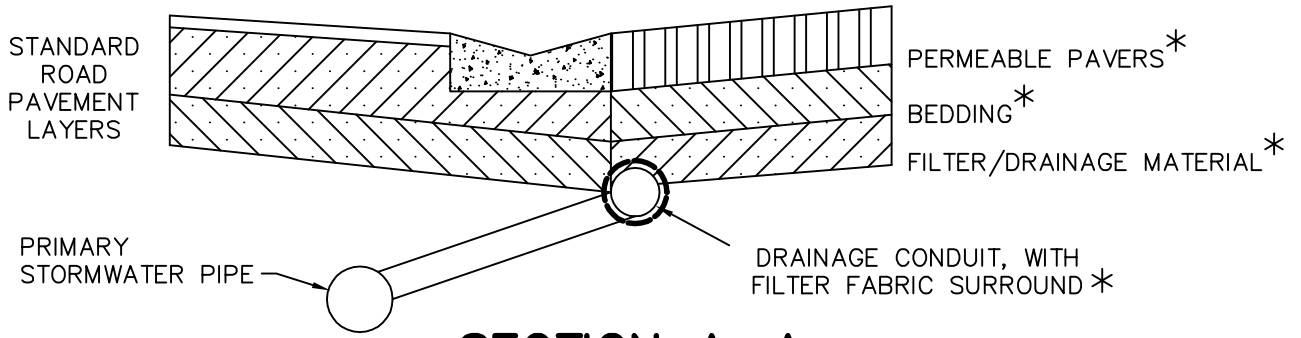

**SECTION A-A**

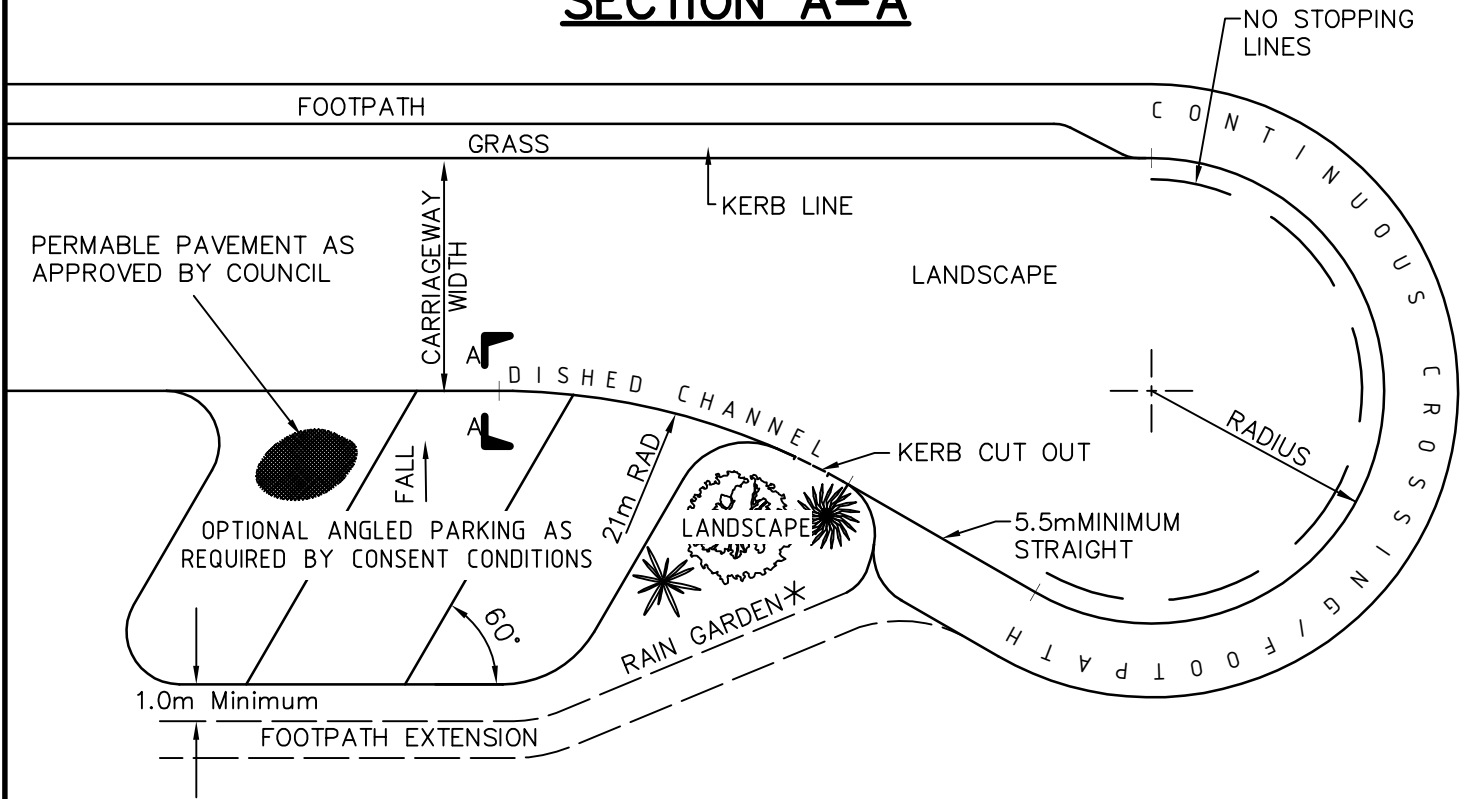

ZONE	RADIUS
RESIDENTIAL	7.0
COMMERCIAL	11.0
INDUSTRIAL	12.0

**NOTE:-**

1. NO KERBSIDE PARKING WITHIN THE TURNING CIRCLE
2. FOR RESIDENTIAL DEVELOPMENT ON STEEP HILLSIDE, THE CUL-DE-SAC RADIUS CAN BE REDUCED TO 7.0m OR A 'FISH-TAIL' OR 'HAMMERHEAD' DESIGN PROVIDED THE TURNING AREA PERMITS A 90 PERCENTILE 2 AXLE TRUCK TO UNDERTAKE A 3 POINT TURN
3. THIS DRAWING IS AN EXAMPLE ONLY AND THERE ARE OTHER COMPLYING DESIGNS FOR CUL-DE-SAC TURNING HEADS

\* (SPECIFIC DESIGN REQUIRED)

<b>NELSON CITY COUNCIL</b>	<b>CUL-DE-SAC TURNING CIRCLES</b>	
	<b>INFRASTRUCTURAL ASSETS</b>	
APPROVED	 SENIOR EXECUTIVE INFRASTRUCTURE	29/07/2010 DATE
		<b>SD 419</b>

CROSSFALL FOR ROADWAY 3%-4% (1 IN 33 - 1 IN 25)

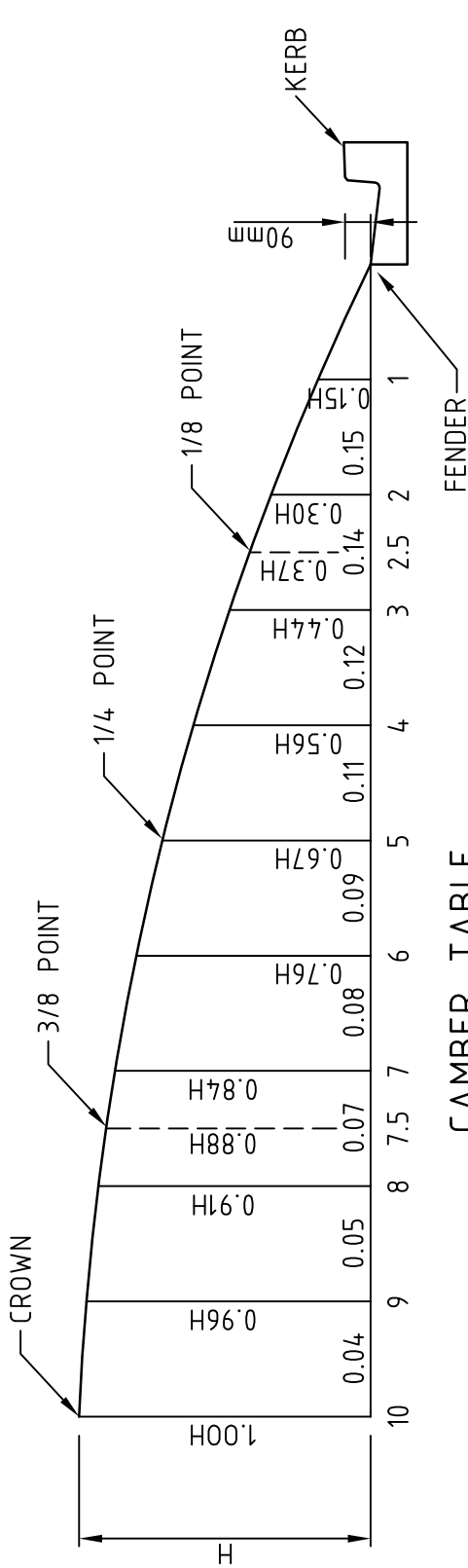

CAMBER TABLE

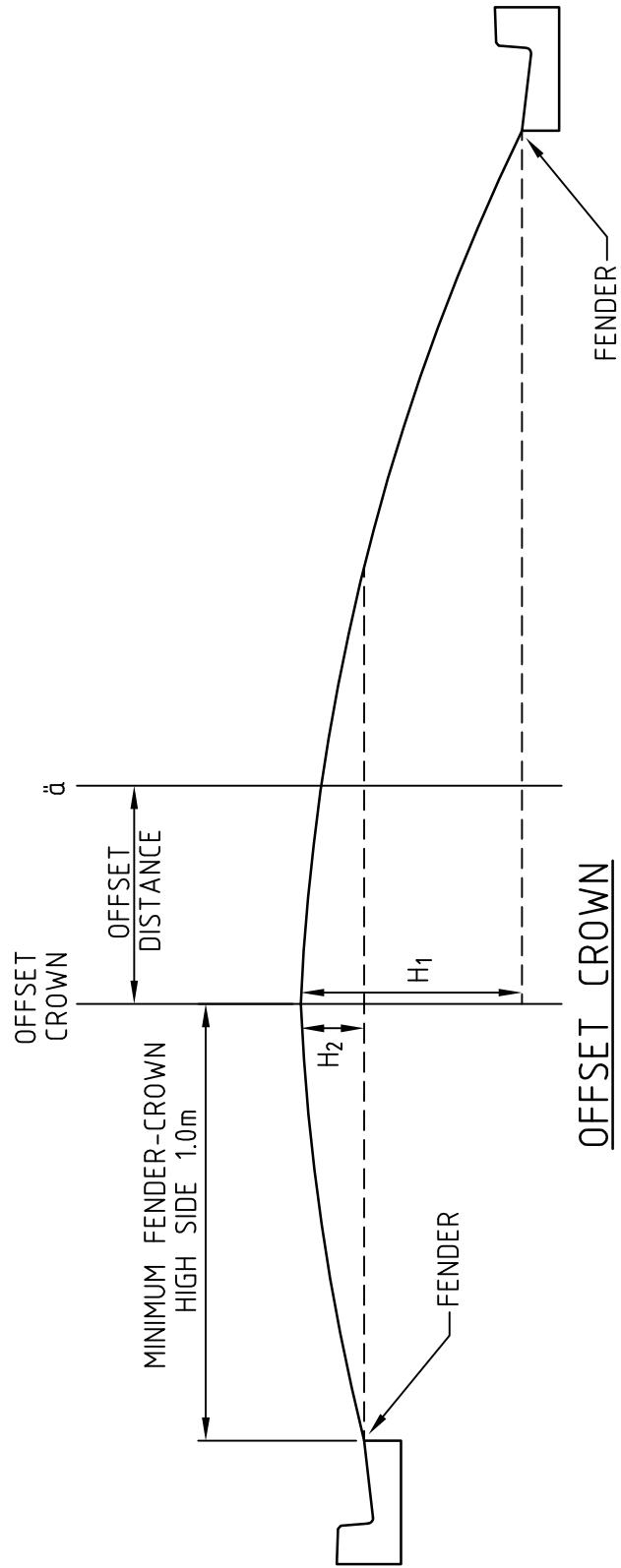

**NOTE:**  
CARRIAGEWAY CAMBER ON EITHER SIDE OF OFFSET CROWN SHOULD BE BALANCED IN TERMS OF THE ABOVE CAMBER TABLES.

**NELSON  
CITY  
COUNCIL**

**CAMBER TABLE**

**INFRASTRUCTURAL ASSETS**

APPROVED

SENIOR EXECUTIVE INFRASTRUCTURE

29/07/2010

DATE

**SD 420**

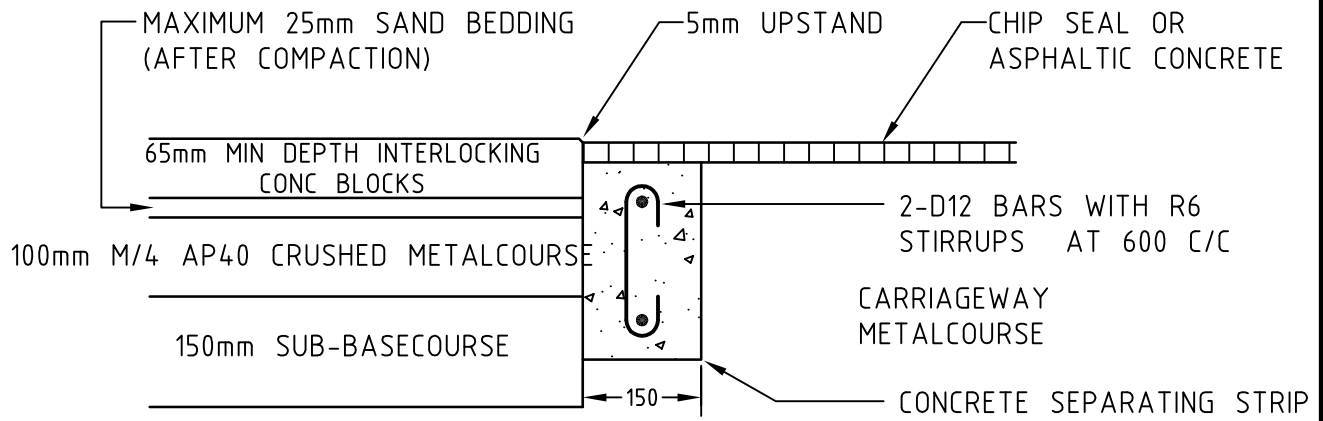

**CARRIAGEWAY THRESHOLDS**  
**(LONGITUDINAL SECTION)**

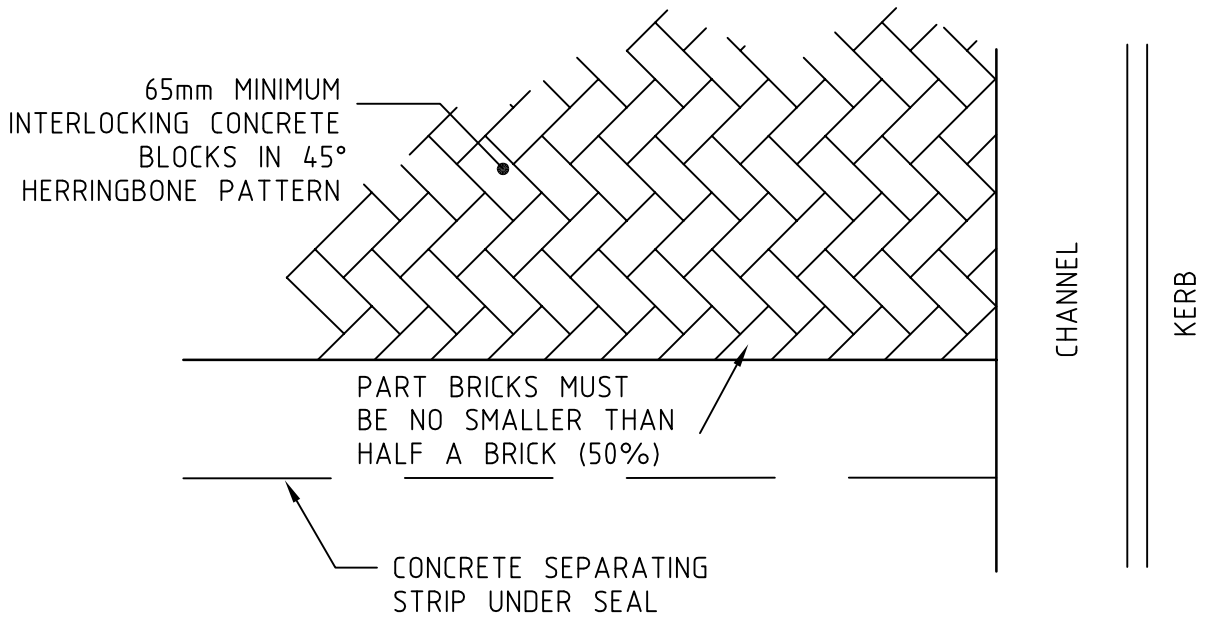

**CARRIAGEWAY THRESHOLDS**  
**PART PLAN**

**NOTES:**

1. CONCRETE BLOCKS SHALL COMPLY WITH NZS 3116: 1981
2. LAYING OF BLOCKS SHALL COMPLY WITH THE CEMENT AND CONCRETE ASSOCIATION OF NZ "INTERLOCKING CONCRETE BLOCK ROAD PAVEMENTS" (SEPT 1988)
3. COLOUR OF BRICKS TO BE NOMINATED ON ENGINEERING DRAWINGS AND APPROVED BY COUNCIL

IN HIGH TRAFFIC AREAS (COLLECTOR ROAD CATEGORY OR HIGHER) THE BLOCKS SHALL BE LAID ON 150mm DEPTH OF REINFORCED CONCRETE AS DETAILED ON SD 423

**NELSON  
CITY  
COUNCIL**

**CARRIAGEWAY THRESHOLDS  
(CONCRETE BLOCKS)**

**INFRASTRUCTURAL ASSETS**

APPROVED

.....  
SENIOR EXECUTIVE INFRASTRUCTURE

29/07/2010

.....  
DATE

**SD 421**

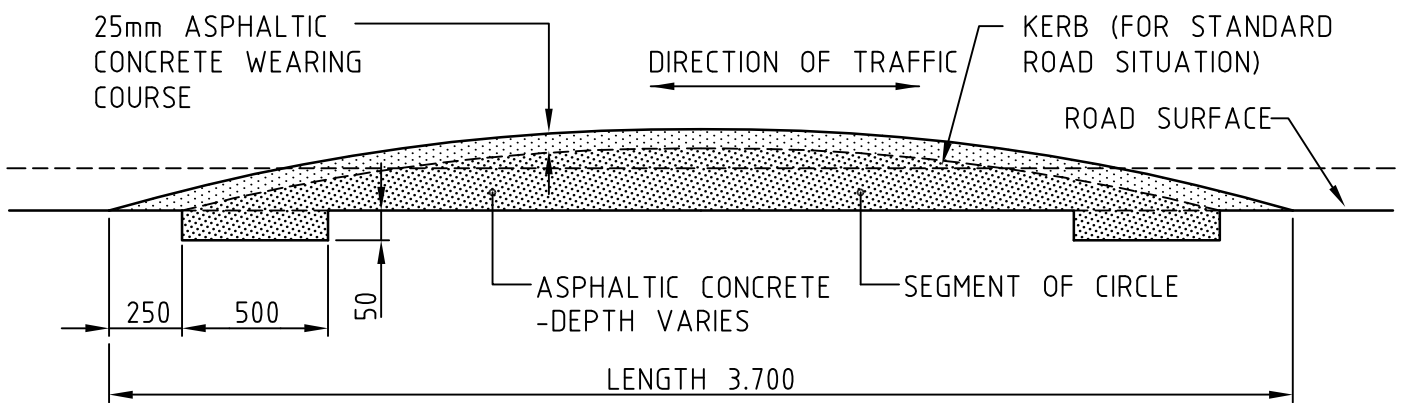
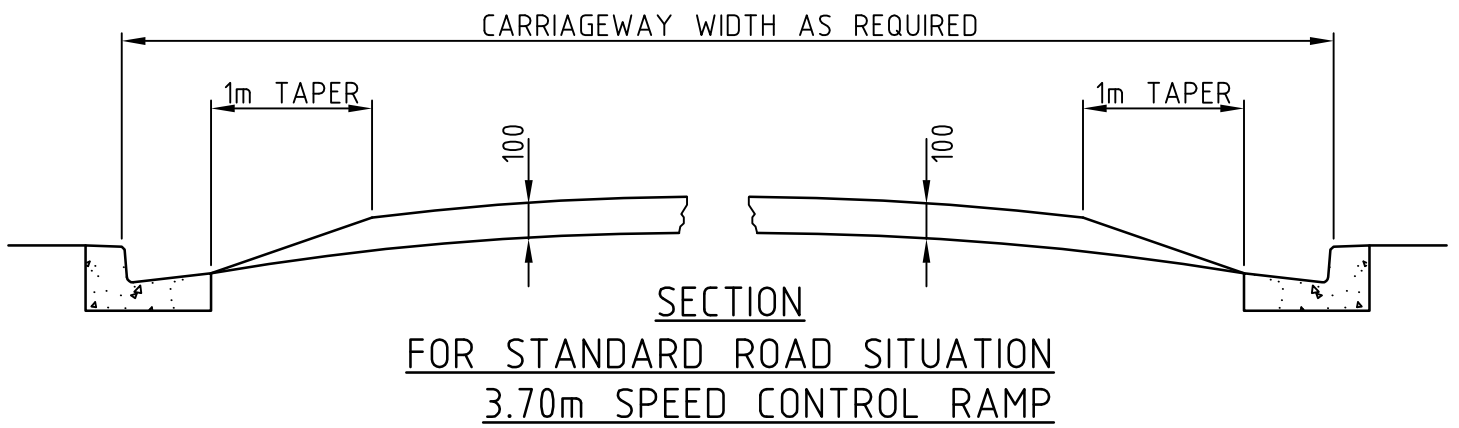

SECTION-SPEED CONTROL RAMP PROFILE  
FOR KERB AND CHANNEL  
STANDARD ROAD SITUATION

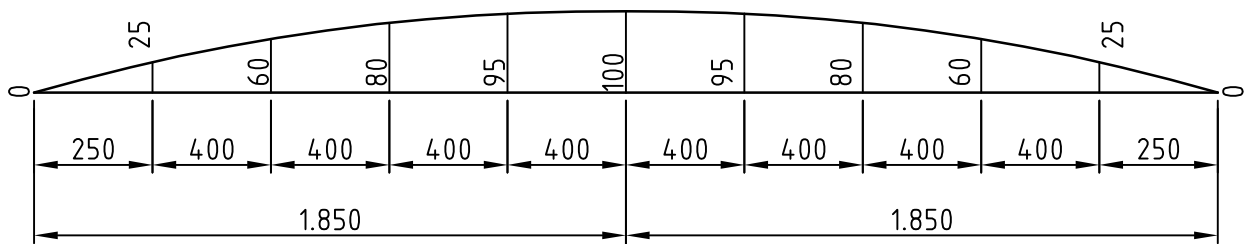

SETTING OUT PROFILE  
FOR SECTION (ALL CASES)

**NELSON  
 CITY  
 COUNCIL**

**SPEED CONTROL DETAILS**

**INFRASTRUCTURAL ASSETS**

APPROVED

.....  
 SENIOR EXECUTIVE INFRASTRUCTURE

29/07/2010

.....  
 DATE

**SD 422**

BRICKS LAID IN 45° HERRINGBONE PATTERN ON 150mm OF CONCRETE (30 MPa) AND 665 MESH. BRICKS TO BE SECURED TO CLEAN SCABBLED CONCRETE WITH AN APPROVED EPOXY BEDDING MORTAR.

1. RAMP HAS MONO CAMBER
2. ONE ROW OF RED PAVERS IN SOLDIER PATTERN TO FACE EACH CONCRETE RAMP
3. JOINTING SAND SHALL BE 'PAVELOCK' OR SIMILAR APPROVED SAND
4. THE MINIMUM SIZE FOR PART BLOCKS/PAVERS SHALL BE 50% OF FULL SIZE

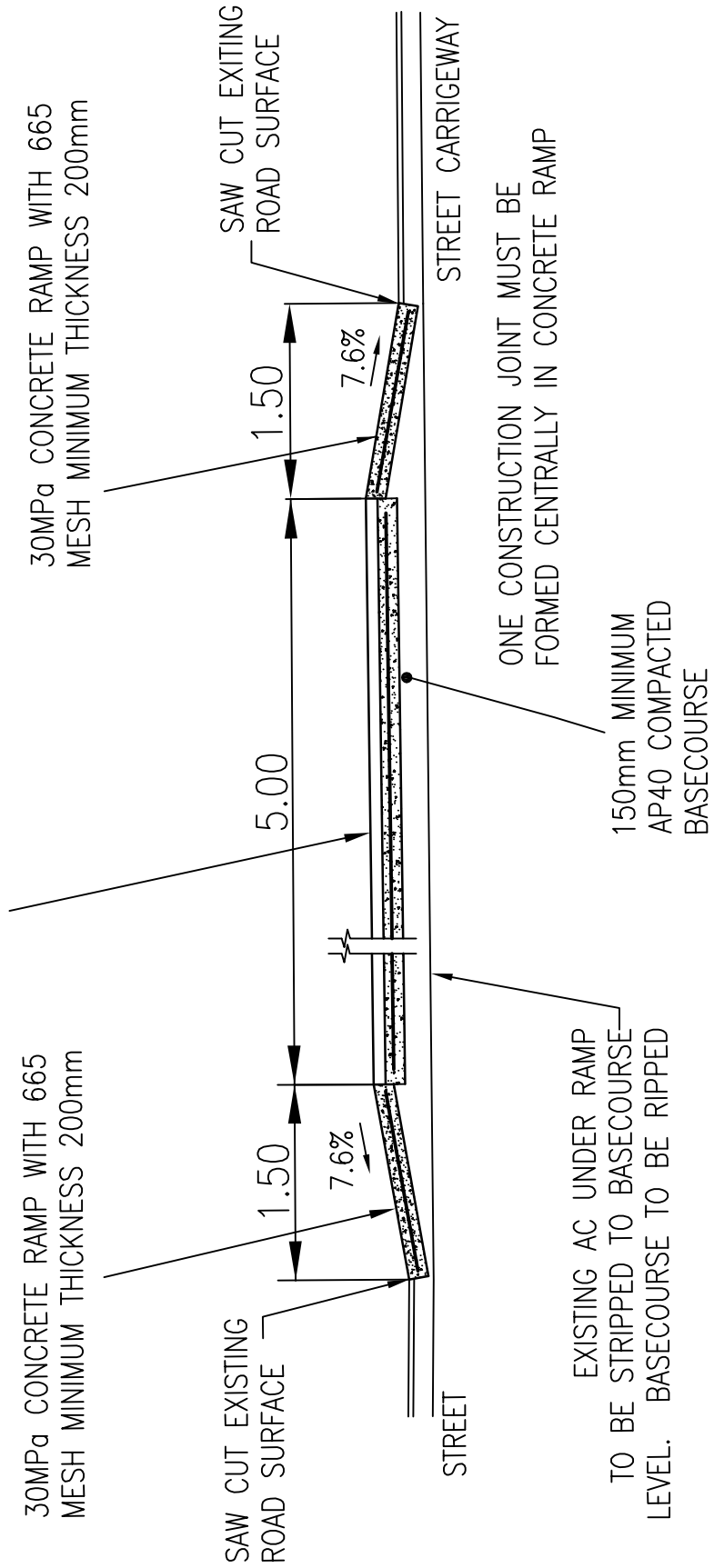

**NELSON  
CITY  
COUNCIL**

**CBD PEDESTRIAN RAMP DETAILS**

**INFRASTRUCTURAL ASSETS**

APPROVED

.....  
SENIOR EXECUTIVE INFRASTRUCTURE

29/07/2010

.....  
DATE

**SD 423**

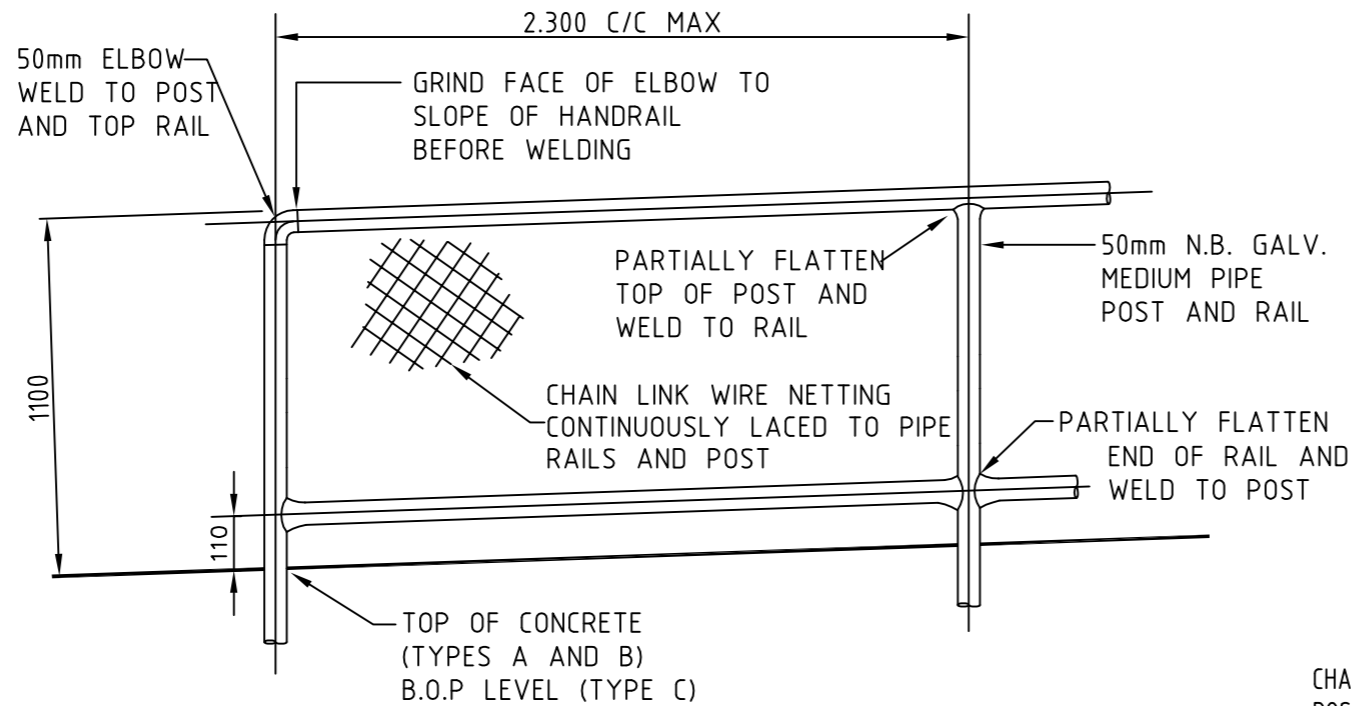

TYPICAL ELEVATION

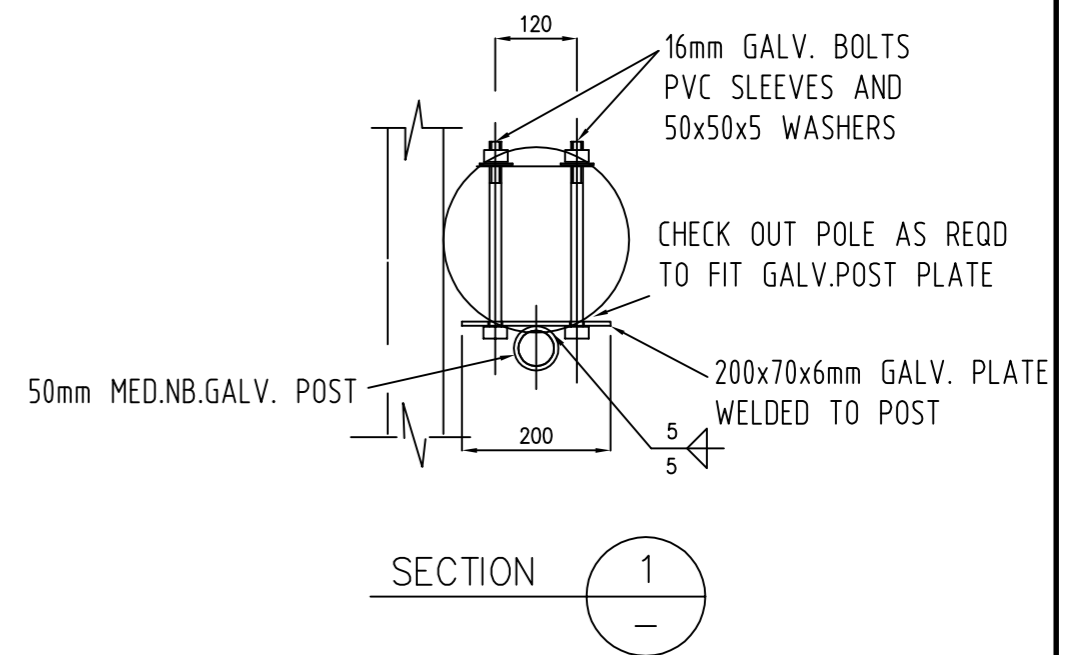

SECTION 1

CHAIN LINK SAFETY FENCE  
 POSTS AT 2.3m CRS WITH 50mm GALV. MESH  
 FIXED TO POST AND RAILS WITH  
 CONTINUOUS SOFT GALV. WIRE LACING.  
 (TYPICAL)

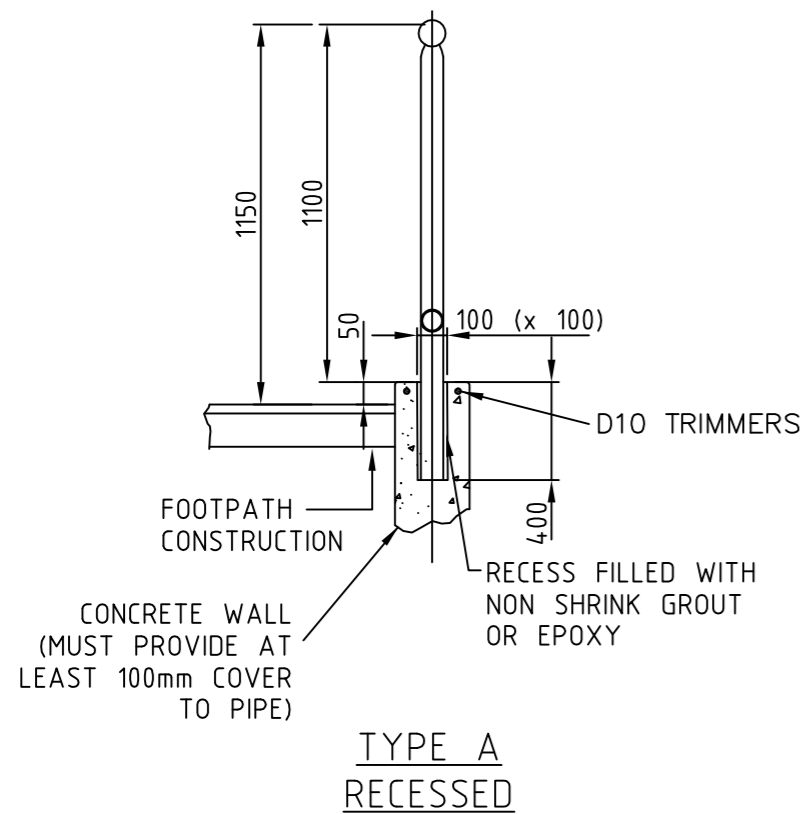

TYPE A  
RECESSED

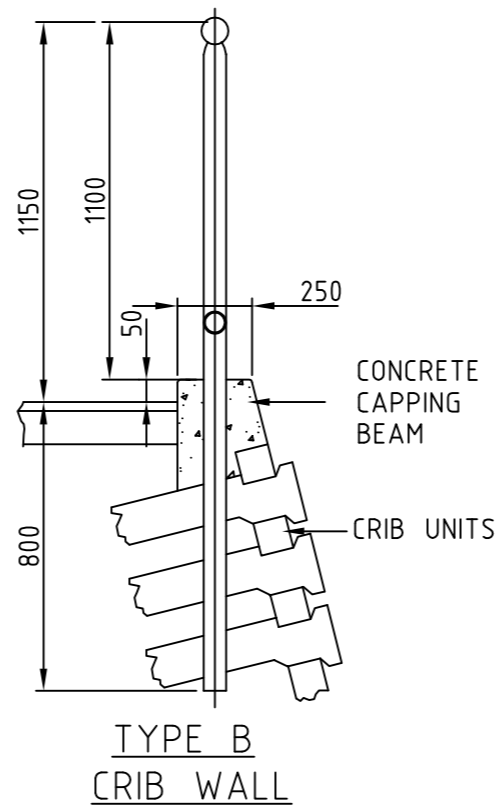

TYPE B  
CRIB WALL

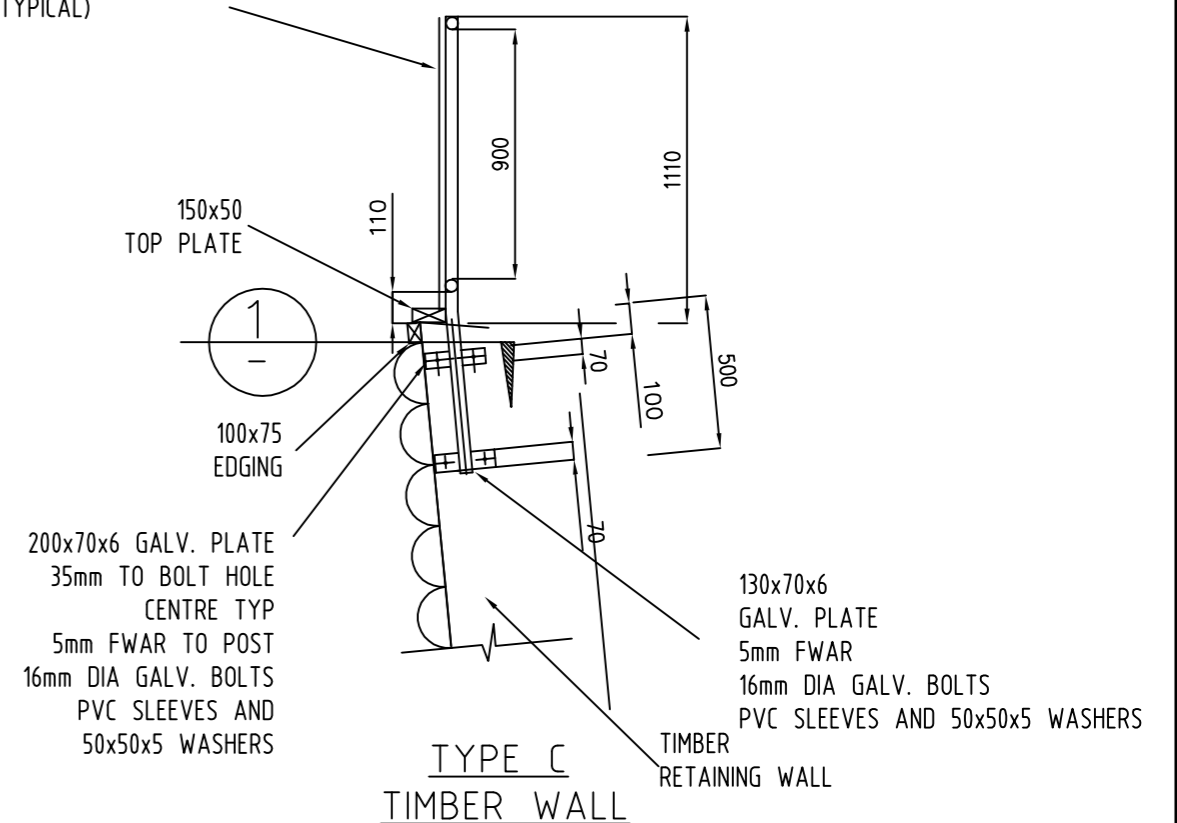

TYPE C  
TIMBER WALL

NOTE:

1. MAXIMUM OPENING SPACE OF THE CHAIN LINK SHALL BE 35mm or 50mm DIAMETER
2. SEE SECTION 4.4.12.4

**NELSON  
CITY  
COUNCIL**

**ALTERNATIVE HANDRAIL  
CHAIN LINK**

**INFRASTRUCTURAL ASSETS**

APPROVED

SENIOR EXECUTIVE INFRASTRUCTURE

29/07/2010

DATE

**SD 424**



**NOTE:**  
 BALUSTRADE TO BE JURALCO VIKING  
 BALUSTRADE (FULL HEIGHT  
 BALUSTRADES) POWDERCOATED  
 ALUMINIUM (INTERPON GHOST GREY)  
 or SIMILAR APPROVED, PROVIDED  
 ALTERNATIVE MEETS REQUIREMENTS  
 B1, B2, & F4 OF THE BUILDING CODE

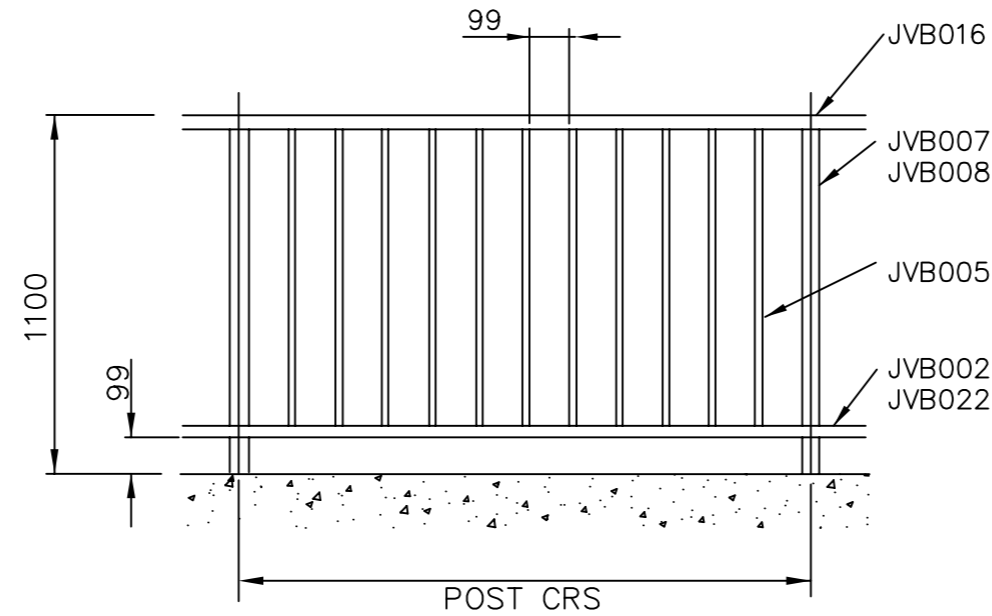

TYPICAL ELEVATION

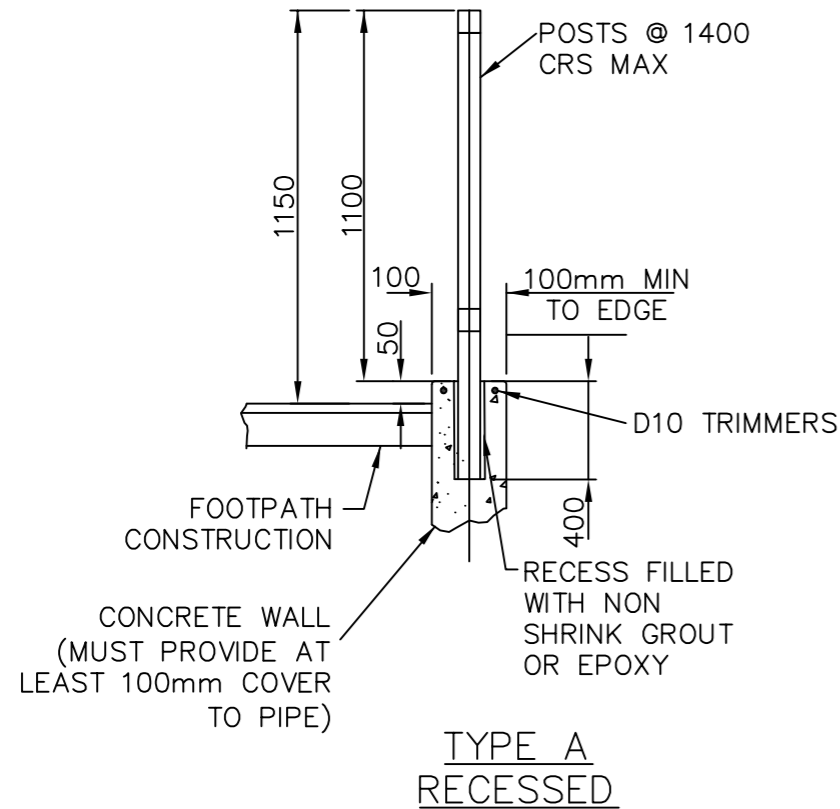

**NOTES:**

1. MINIMUM COVER TO D10 REINFORCING FROM EXPOSED SURFACE SHALL BE 50mm
2. FOR TIMBER WALL FIXING DETAIL, SEE TYPE 'C' ON SD 424
3. SEE SECTION 4.4.12.4

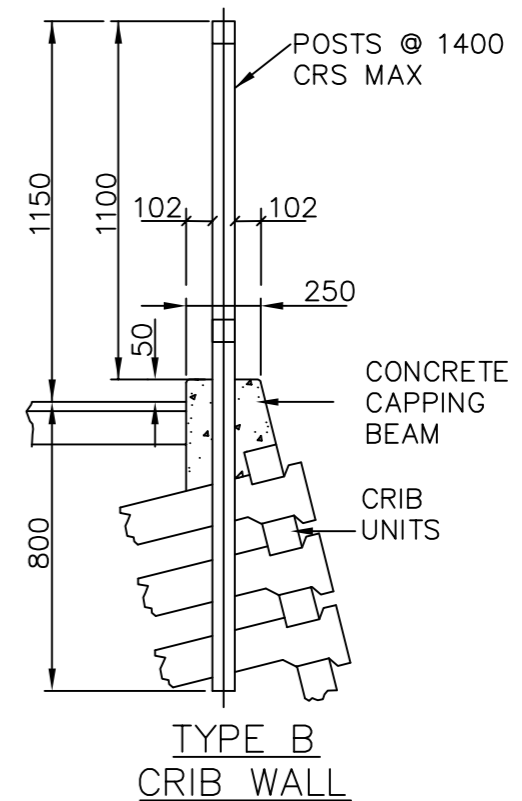

**NELSON  
 CITY  
 COUNCIL**

**STANDARD HANDRAIL –  
 BALUSTRADES**

**INFRASTRUCTURAL ASSETS**

APPROVED

SENIOR EXECUTIVE INFRASTRUCTURE

29/07/2010

DATE

**SD 425**

PLASTER CAP PERMANENTLY  
AFFIXED WITH DOWEL  
STARTER AND PAINTED  
WHITE.

300mm OF 140mmØ  
GALVANISED PIPE, 4mm THICK,  
INSERTED AND PERMANENTLY  
AFFIXED INTO 150mmØ  
GALVANISED PIPE.

PADLOCK BRACKET  
(SEE DETAIL BELOW)

150mm  
GALVANISED  
PIPE 4mm  
THICK

FINISHED SURFACE

D12 STIRRUP

4 - D12 BARS  
MIN 50mm FROM PIPE  
MIN COVER 50mm

600mm x 500mm  
DEEP 28 MP<sub>a</sub>  
CONCRETE FOUNDATION.

**ELEVATION**

**NOTES:**

1. ALL STEELWORK SHALL BE PRIMED AND PAINTED WHITE WITH REFLECTORISED STRIPS VISIBLE FROM BOTH WAYS
2. PADLOCK TO BE POSITIONED FACING DIRECTION OF CYCLE TRAFFIC

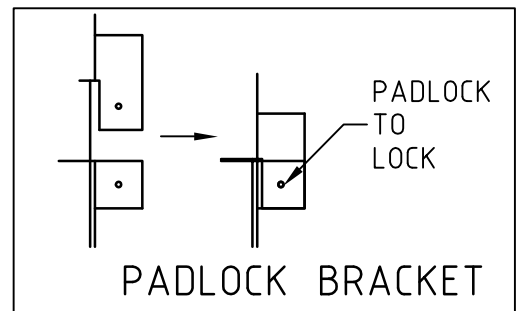

**NELSON  
CITY  
COUNCIL**

**REMOVABLE CYCLE BOLLARD**

**INFRASTRUCTURAL ASSETS**

APPROVED

SENIOR EXECUTIVE INFRASTRUCTURE

29/07/2010

DATE

**SD 426**

PLASTER CAP PERMANATELY  
AFFIXED WITH DOWEL  
STARTER AND PAINTED  
WHITE.

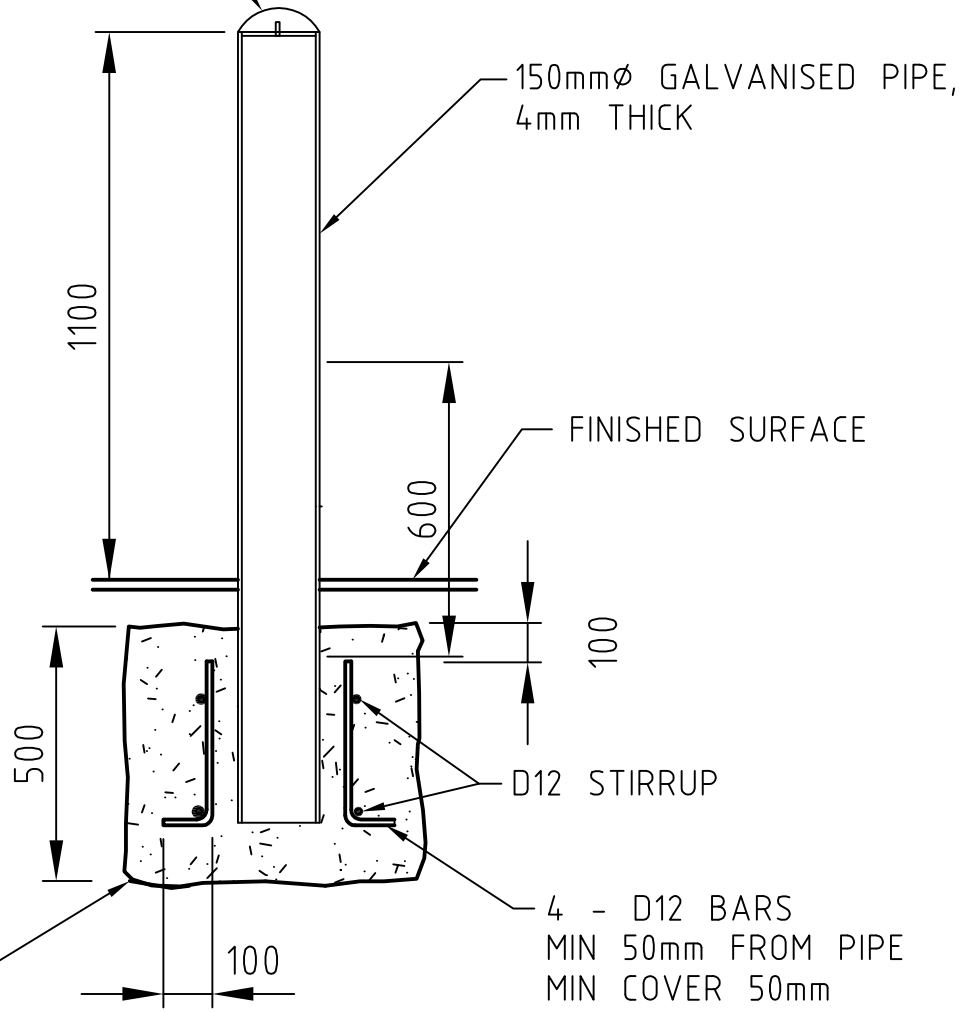

600mm x 500mm  
DEEP 28 MP<sub>a</sub>  
CONCRETE FOUNDATION.

**ELEVATION**

**NOTES:**

× ALL STEELWORK SHALL BE PRIMED AND PAINTED WHITE  
WITH REFLECTORISED STRIPS VISABLE FROM BOTH WAYS

**NELSON  
CITY  
COUNCIL**

**STANDARD CYCLE BOLLARD**

**INFRASTRUCTURAL ASSETS**  
APPROVED   
.....  
SENIOR EXECUTIVE INFRASTRUCTURE

29/07/2010  
.....  
DATE

**SD 427**

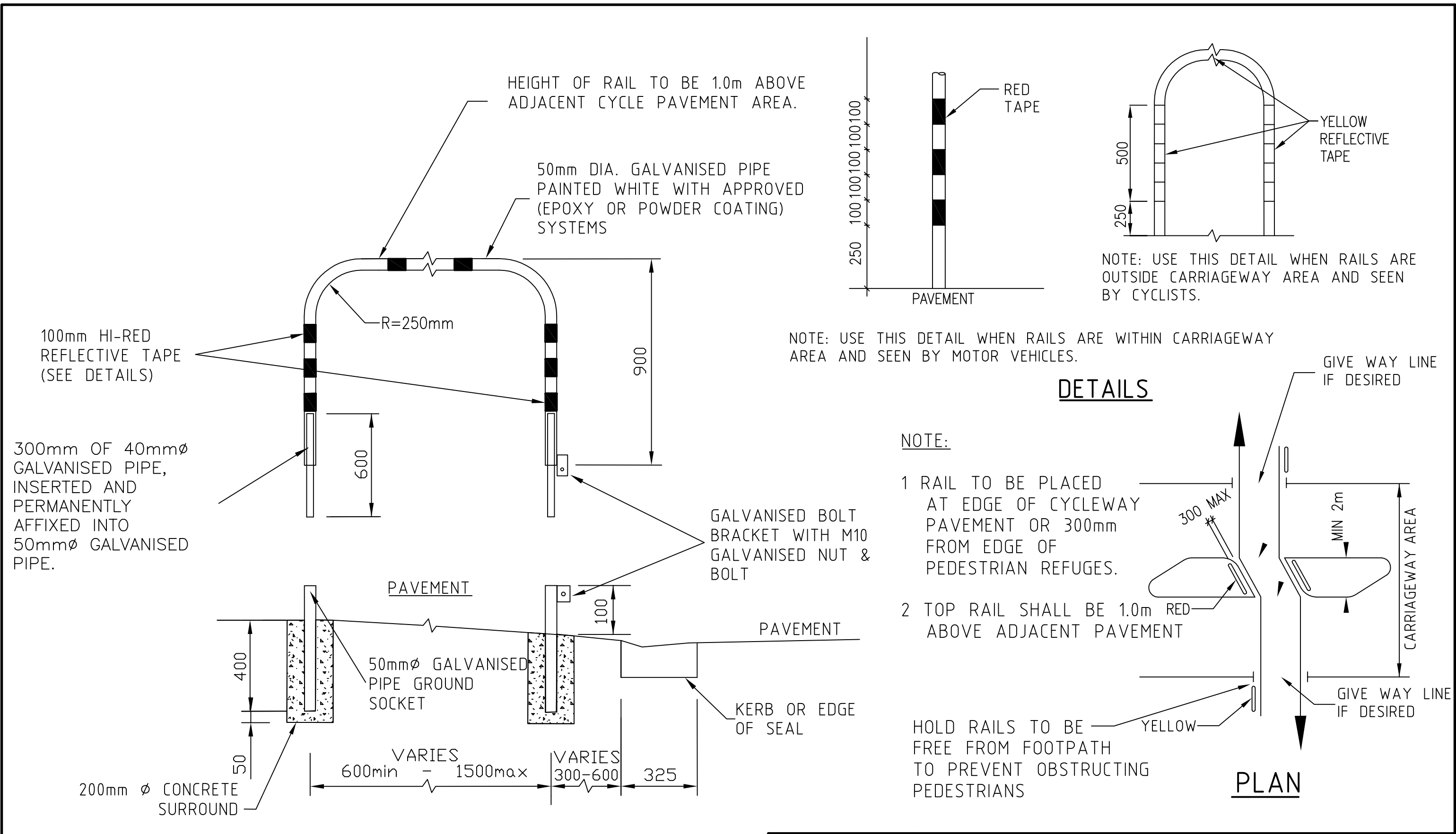

HOLDING RAIL ELEVATION

<b>NELSON CITY COUNCIL</b>	<b>CYCLE HOLDING RAIL</b>	
	<b>INFRASTRUCTURAL ASSETS</b> APPROVED  29/07/2010 SENIOR EXECUTIVE INFRASTRUCTURE DATE	<b>SD 428</b>

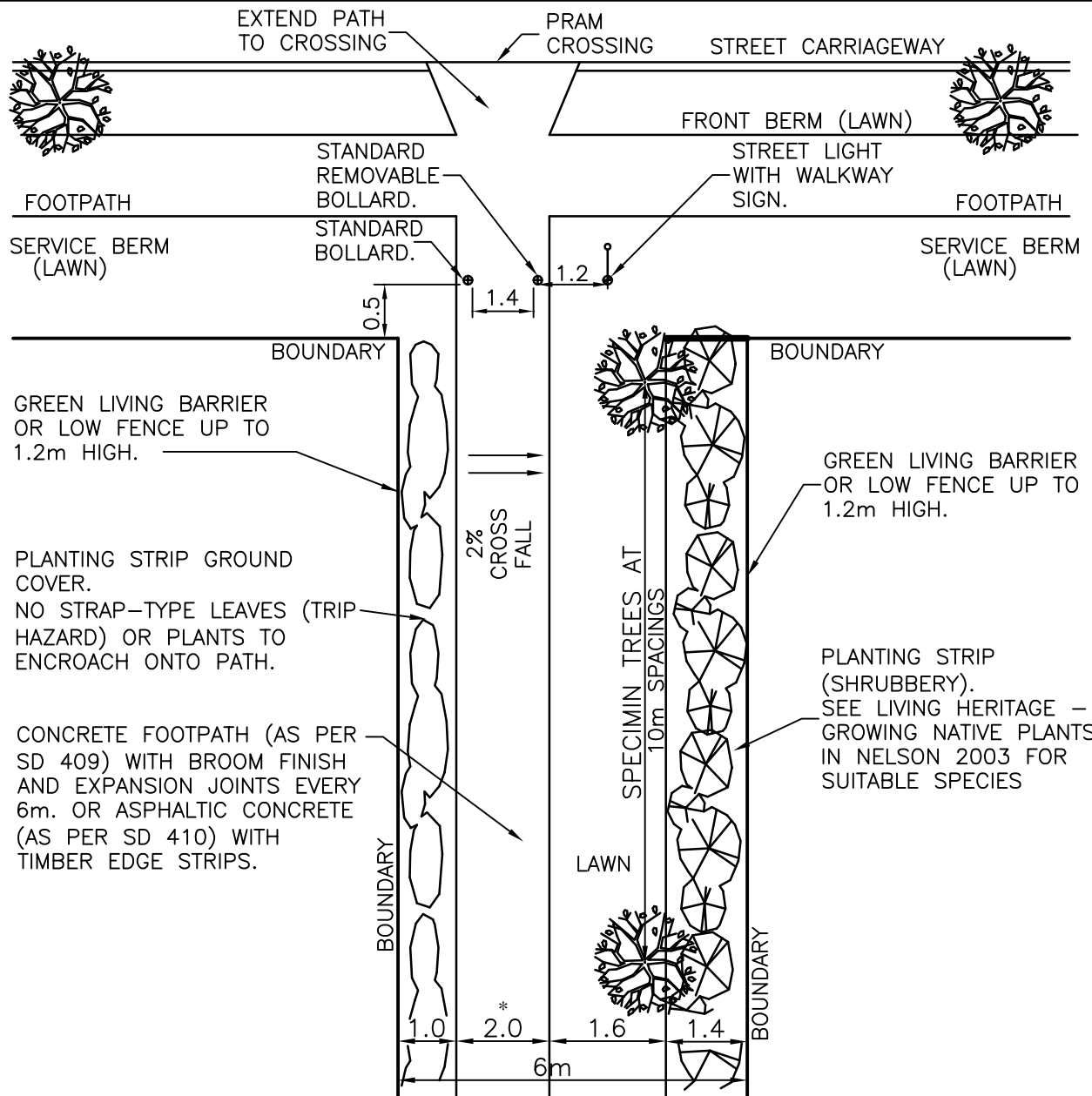

NOTE:  
 \* THE PEDESTRIAN/CYCLE ACCESS IS TO BE USED TO LINK A ROAD TO A ROAD OR ROAD TO RESERVE. FOR SHARED ACCESSWAYS THAT ARE ON A MAIN ROUTE & WILL HAVE A HIGH USE, THEN THE SEALED PATHWAY SHALL BE 3.0m & SUBJECT TO SPECIFIC DESIGN. SEE TABLE 4-15

WITH WALKWAYS ORIENTED EAST/WEST PLANT TREES ON THE NORTHERN SIDE OF THE FOOTPATH.

IF STEPS ARE REQUIRED FOR GRADES GREATER THAN 1:5 THEN STREET LIGHTING SHALL BE PROVIDED AS WELL AS A HANDRAIL TO ONE SIDE. ALSO, A HALF-ROUND OPEN CONCRETE CHANNEL SHALL BE FORMED ADJACENT THE STEPS TO ASSIST CYCLE MOVEMENT,

STEPS SHALL BE NO NARROWER THAN 300mm TREAD WITH 150-180 RISER. A LANDING SHALL BE PROVIDED EVERY 20 STEPS. NO LESS THAN 3 STEPS SHALL BE PROVIDED IN ANY ONE AREA.

FOR BOLLARD DETAILS SEE SD 426 & SD 427

**NELSON  
 CITY  
 COUNCIL**

**ACCESSWAY**

**COMMUNITY SERVICES**

APPROVED

*P. M. Anthony*  
 .....  
 MANAGER PARKS & FACILITIES

29/07/2010

DATE

**SD 429**